

# **TB-24P/24R/16P8R**

Relay Outputs or Isolated Inputs  
Terminal Board Series



@Copyright 1995~1998 ADLink Technology Inc.  
All Rights Reserved.

Manual first edition: 15, August 1995  
Manual second edition: 01, March 1998

The information in this document is subject to change without prior notice in order to improve reliability, design and function and does not represent a commitment on the part of the manufacturer.

In no event will the manufacturer be liable for direct, indirect, special, incidental, or consequential damages arising out of the use or inability to use the product or documentation, even if advised of the possibility of such damages.

This document contains proprietary information protected by copyright. All rights are reserved. No part of this manual may be reproduced by any mechanical, electronic, or other means in any form without prior written permission of the manufacturer.

**Trademarks**

TB-24P, TB-24R, TB-16P8R are registered trademark of ADLink Technology Inc., other product names mentioned herein are used for identification purposes only and may be trademarks and/or registered trademarks of their respective companies.



# CONTENTS

How to Use This Guide .....	iii
<b>TB-24P : 24 Opto-isolated Digital Inputs Terminal Board .....</b>	<b>1</b>
1.1 Introductions .....	1
1.2 Specifications.....	1
1.3 Descriptions .....	2
<b>TB-24R : 24 Relay Outputs Terminal Board.....</b>	<b>7</b>
2.1 Introduction .....	7
2.2 Specification.....	7
2.3 Description .....	8
<b>TB-16P8R : 16 Opto-isolated Inputs &amp; 8 Relay Outputs Terminal Board.....</b>	<b>13</b>
3.1 Introduction .....	13
3.2 Specification.....	13
3.3 Description .....	14
<b>Product Warranty/Service .....</b>	<b>19</b>



# How to Use This Guide

This manual is designed to help you use the TB-24P/24R/16P8R. The manual describes how to modify various settings on the TB-24P/24R/16P8R card to meet your requirements.

- Chapter 1, "TB-24P : 24 Opto-isolated Digital Inputs Terminal Board", gives an overview of the TB-24P's features, description, and specifications.
- Chapter 2, "TB-24R : 24 Relay Outputs Terminal Board", gives an overview of the TB-24R's features, description, and specifications.
- Chapter 3, "TB-16P8R ; 16 Opto-isolated Digital Inputs & 8 Relay Outputs Terminal Board", gives an overview of the TB-16P8R features, description, and specification



# 1

## TB-24P : 24 Opto-isolated Digital Inputs Terminal Board

---

### 1.1 Introductions

TB - 24P is an input extension board with 24 isolated photo couplers. CN1, CN2, CN3 and CN4 are terminal blocks to connect with external devices. CN5 is a 50 pins connector to connect with opto-22 compatible connector, such as ACL-7124, ACL-7122, PET-48DIO, etc. All input ports are with LED indicators.

---

### 1.2 Specifications

Indication Display	: 24 LEDs for input indication
Input electrical characteristics	
Logic input low voltage	: <0.8 V DC
Logic input high voltage	: +3V DC to +24V DC
Logic input high current	: 6.3mA to 50mA
Logic "1"	: Voltage input high
Logic "0"	: Voltage input low
Isolation voltage	: 2500V DC

---

## 1.3 Descriptions

TB-24P has 5 connectors and 24 LEDs. The following Figure shows their placement on TB-24P.

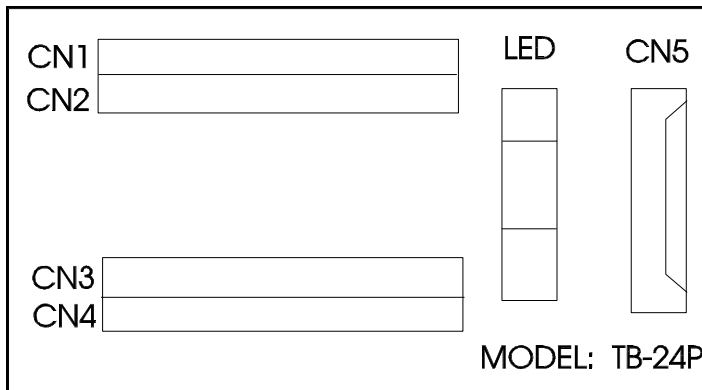

**Outline of TB-24P**

TB-24P has 24 LEDs to indicate input status, the LED mapping and logic define shows as following table.

LED No.	Indication Display	Color of LED	Channel
LED 0	PA0	GREEN	CH0
LED 7	PA7	GREEN	CH7
LED8	PB0	YELLOW	CH8
LED 15	PB7	YELLOW	CH15
LED 16	PC0	RED	CH16
LED 23	PC7	RED	CH23

**LED mapping table**

Logic "1"	LED "ON"
Logic "0"	LED "OFF"

**Logic define**

Each input channel can connect with opto-22 compatible Digital I/O board, such as ACL-7122, PET-48DIO, etc. directly or through photo coupler, and the upper of each photo coupler has a jumper to select.

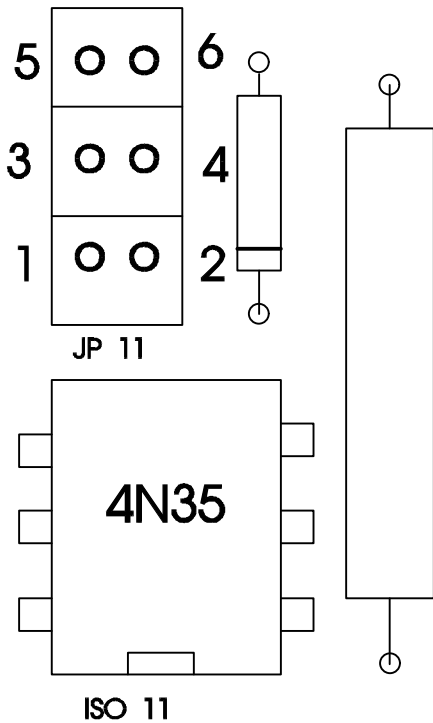

**The position of each setting jumper**

Each input port has two mini jumpers for setting.

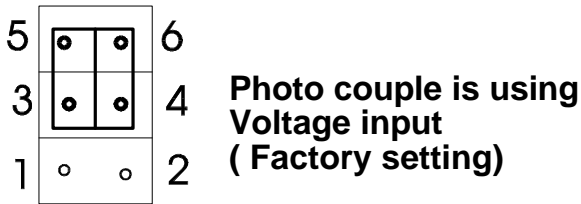

The input circuit shows as figure.

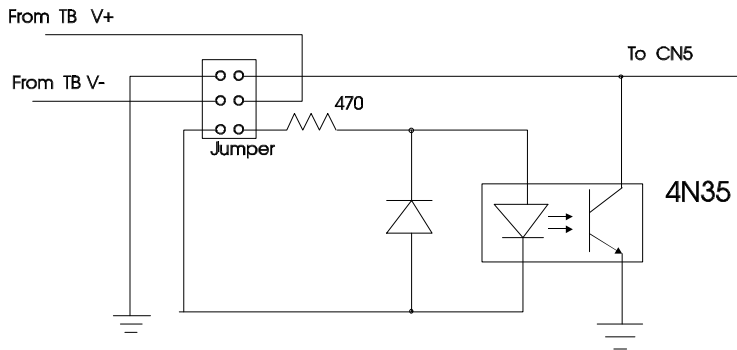

Each input channel has two terminal blocks. The terminal block pins' define as following figure.

**CN1**

CH12		CH14		CH16		CH18		CH20		CH22	
V	V	V	V	V	V	V	V	V	V	V	V
+	-	+	-	+	-	+	-	+	-	+	-

**CN2**

CH13		CH15		CH17		CH19		CH21		CH23	
V	V	V	V	V	V	V	V	V	V	V	V
+	-	+	-	+	-	+	-	+	-	+	-

**CN3**

CH0		CH2		CH4		CH6		CH8		CH10	
V	V	V	V	V	V	V	V	V	V	V	V
+	-	+	-	+	-	+	-	+	-	+	-

**CN4**

CH1		CH3		CH5		CH7		CH9		CH11	
V	V	V	V	V	V	V	V	V	V	V	V
+	-	+	-	+	-	+	-	+	-	+	-

The CN5 is an opto-22 compatible connector, its pin assignment shows as following figure.

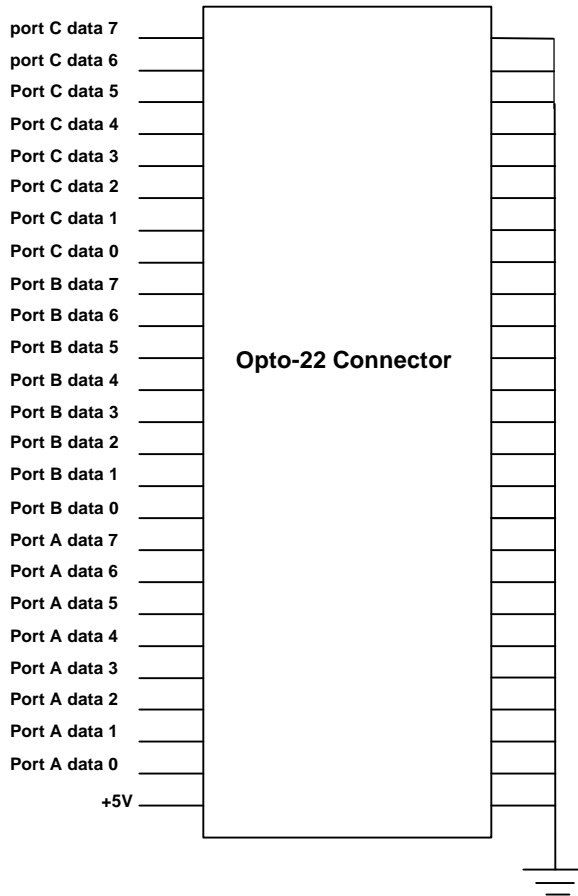

**CN5 pins define figure**

# 2

## TB-24R : 24 Relay Outputs Terminal Board

---

### 2.1 Introduction

TB - 24R is an output extension board with 24 relays. CN1, CN2, CN3 and CN4 are terminal blocks to connect with external devices. CN5 connect with external power source. TB-24R/12 using +12V power, but TB-24R/24 using +24V power. CN6 is to connect the opto-22 compatible connector, such as ACL-7122, ACL-7124, PET-48DIO, etc.

---

### 2.2 Specification

Indication display : 24 LEDs  
Relay type : High sensitive 1500 V FCC surge with standing miniature relay.  
Relay form : SPDT  
Contact rating :

Max. switching power	60 W, 125 VA
Max. switching voltage	220 V DC, 250 V AC
Max. switching current	2 A DC, AC
Max. carrying current	3 A DC, AC
UL/CSA rating	0.6 A 125 V AC
UL/CSA rating	0.6 A 110 V DC
UL/CSA rating	2 A 30 V DC

**Coil voltage** : 12 V DC for TB-24R/12  
: 24V DC for TB-24R/24

## 2.3 Description

TB-24R has six connectors. The figure as below is placement of these connector.

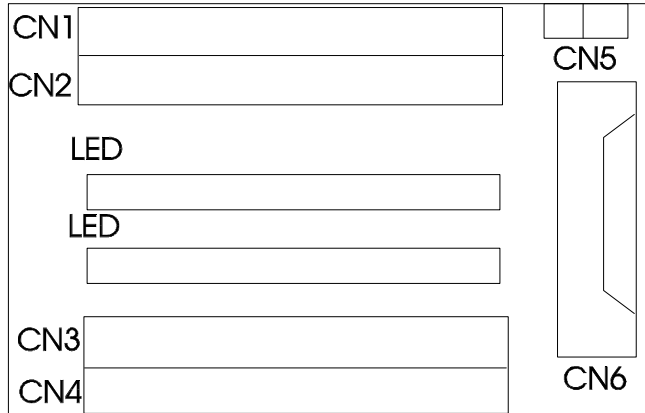

**Outline of TB - 24R**

The 24 LEDs are indicators of output ports. The mapping of LED and Logic define are showing as table.

LED No.	Indication Display	Color of LED	Channel
LED0	PA0	GREEN	CH0
LED7	PA7	GREEN	CH7
LED8	PB0	YELLOW	CH8
LED15	PB7	YELLOW	CH15
LED16	PC0	RED	CH16
LED23	PC7	RED	CH23

**LEDs Mapping Table**

Logic "1"	LED " ON"
Logic "0"	LED "OFF"

**Logic Define Table**

CN1, CN2, CN3 and CN4 are terminal blocks to connect with external device.

Each output channel has three terminal blocks to connect, the define is showing as figure.

<b>Channel No.</b>		
<b>Common</b>	<b>Normal close</b>	<b>Normal open</b>

**Terminal block define of each channel**

The relationship of channel No. and CN1, CN2, CN3, CN4 are showing as figure.

**CN1**

<b>CH12</b>	<b>CH14</b>	<b>CH16</b>	<b>CH18</b>	<b>CH20</b>	<b>CH22</b>
<b>CH13</b>	<b>CH15</b>	<b>CH17</b>	<b>CH19</b>	<b>CH21</b>	<b>CH23</b>

**CN2**

**CN3**

<b>CH0</b>	<b>CH2</b>	<b>CH4</b>	<b>CH6</b>	<b>CH8</b>	<b>CH10</b>
<b>CH1</b>	<b>CH3</b>	<b>CH5</b>	<b>CH7</b>	<b>CH9</b>	<b>CH11</b>

**CN4**

The relationship of channel and CN1,CN2,CN3,CN4

The CN5 is to connect with external power source. Figure shows CN5 connecting.

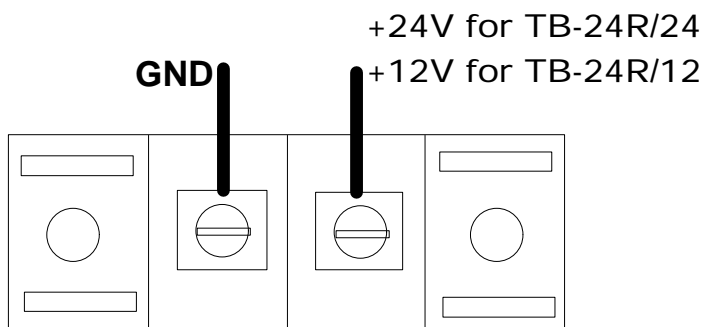

**CN5 connecting**

The output circuit shows as figure.

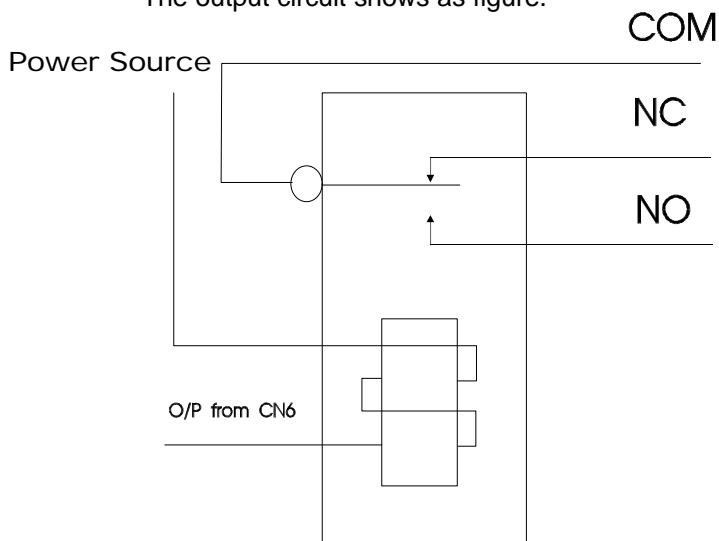

TB-24R/12: Relay is DSIE-S-DC12V, it need +12V power source

TB-24R/24: Relay is DSIE-S-DC24V, it need +24V power source

The CN6 is to connect with opto-22 compatible connector, such as ACL-7122, ACL-7124, or PET-48DIO, etc. Its pin assignment is defined as following figure.

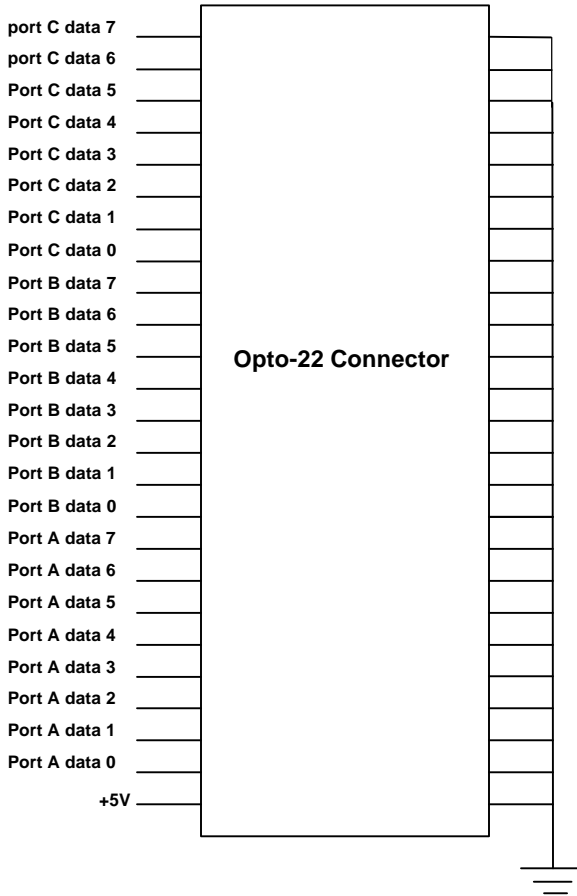

**CN6 pins' define figure**



# 3

## TB-16P8R : 16 Opto-isolated Inputs & 8 Relay Outputs Terminal Board

---

### 3.1 Introduction

The TB-16P8R is input / output extension board with 16 input ports and 8 output ports. All input ports are with photo couplers, and all outputs are with relays. Terminal blocks on TB-16P8R are to connect with external devices. Photo coupler of input port is able to by pass the same as TB-24P.

---

### 3.2 Specification

Indication Display	: 24 LEDs for input/output indication
Input electrical characteristically:	
Logic input low voltage	: < 0.8 V DC
Logic input high voltage	: +3V DC to +24V DC
Logic input high current	: 6.3mA to 50mA
Logic "1"	: Voltage input high
Logic "0"	: Voltage input low
Isolation voltage	: 2500V DC
Relay type	: High sensitive 1500 V FCC surge with standing miniature relay.
Relay form	: SPDT

Contact rating:

Max. switching power	60 W, 125 VA
Max. switching voltage	220 V DC, 250 V AC
Max. switching current	2 A DC, AC
Max. carrying current	3 A DC, AC
UL/CSA rating	0.6 A 125 V AC
UL/CSA rating	0.6 A 110 V DC
UL/CSA rating	2 A 30 V DC

**Coil voltage: 12 V DC for TB-16P8R/12**  
**24 V DC for TB-16P8R/24**

---

### 3.3 Description

TB-16P8R has 6 connectors and 24 LEDs. The following Figure shows the placement on TB-16P8R.

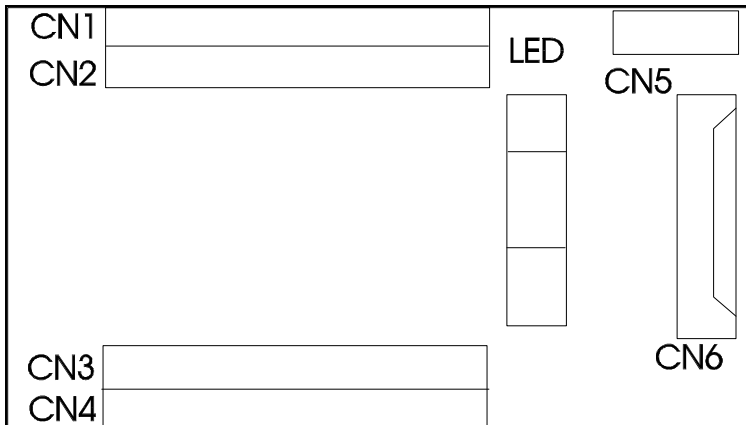

**TB-16P8R Outline**

The CN5 is to connect with external power source.  
 The CN1, CN2 are terminal block for input connecting.  
 The CN3, CN4 are terminal block for output connecting.  
 The CN6 is to connect with the opto-22 compatible connector,  
 such as ACL-7122 or PET-48DIO. (Please set the I/O mode as  
 mode 7).

The design of input port is same as TB-24P. JP8 to JP23 are  
 for dry contact or using photo coupler setting.

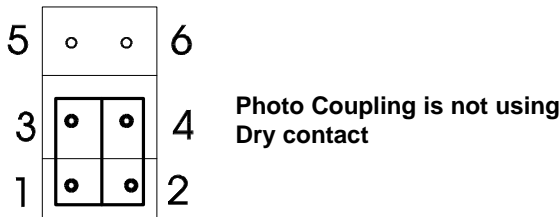
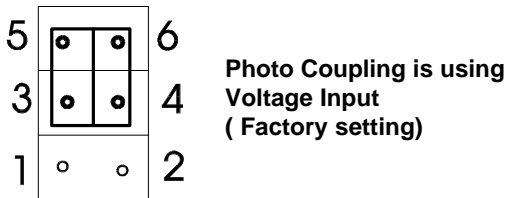

The input port of TB-16P8R is same as TB-24P. Each input  
 channel has two terminal blocks. The pins' define of CN1, CN2  
 is showing as following figure.

**CN1**

CH 8		CH 10		CH 12		CH 14		CH 16		CH 18		CH 20		CH 22	
V	V	V	V	V	V	V	V	V	V	V	V	V	V-	V	V
+	-	+	-	+	-	+	-	+	-	+	-	+	-	+	-

**CN2**

CH9		CH11		CH13		CH15		CH17		CH19		CH21		CH23	
V	V	V	V	V	V	V	V	V	V	V	V	V	V	V	V
+	-	+	-	+	-	+	-	+	-	+	-	+	-	+	-

The output port of TB-16P8R is same as TB-24R. Each output channel has three terminal blocks.

Channel No.		
Common	Normal close	Normal open

The relationship of channel and CN3, CN4 is showing as table.

**CN3**

CH0	CH2	CH4	CH6
CH1	CH3	CH5	CH7

**CN4**

The relationship of LED, channel and output port is showing as table.

LED No.	Indication Display	Color of LED	Channel
LED 0	PA0	GREEN	CH0
LED 7	PA7	GREEN	CH7
LED8	PB0	YELLOW	CH8
LED 15	PB7	YELLOW	CH15
LED 16	PC0	RED	CH16
LED 23	PC7	RED	CH23

The CN5 is to connect external power source. Figure shows connecting.

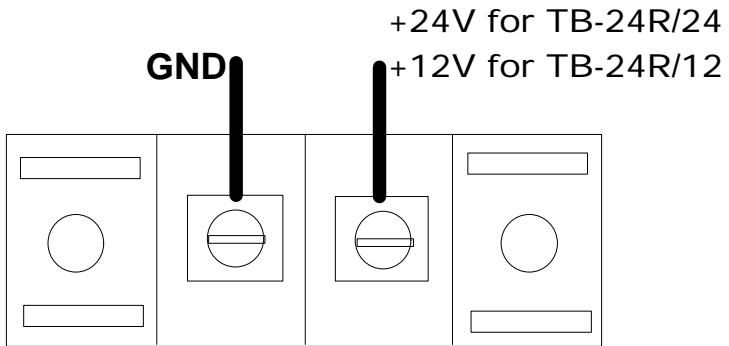

TB-16P8R/12: Relay is DSIE-S-DC12V, it need +12V power source

TB-16P8R/24: Relay is DSIE-S-DC24V, it need +24V power source

The CN6 is connector to connect with opto-22 compatible connector. Figure shows CN6 pins' define.

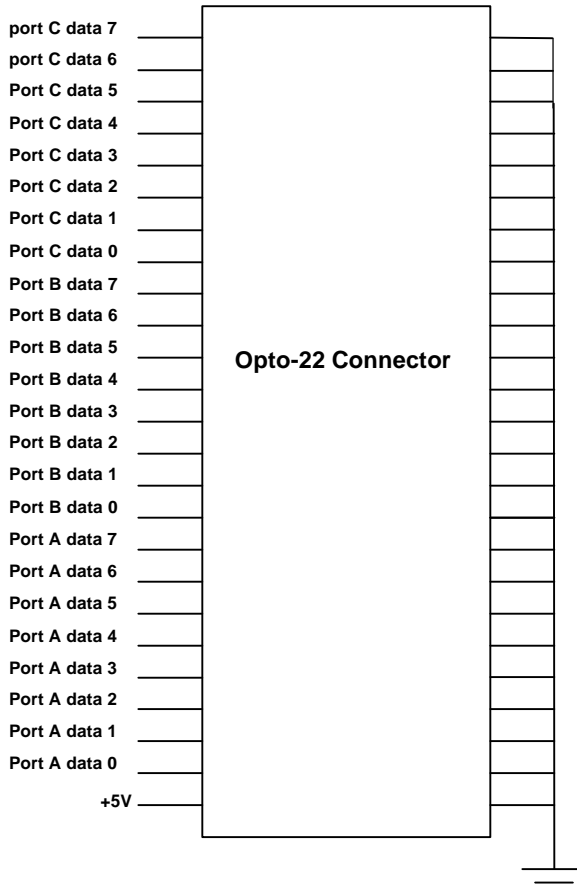

**CN6 pins' define**

**PORT A : Relay Output**

**PORT B,C : Opto-isolated Input**

The 8 relay output ports (8R) connects with PET-48DIO port A through CN6, and 16 photo coupler input ports (16p) connects with PET-48DIO port B,C through CN6.

# Product Warranty/Service

Seller warrants that equipment furnished will be free from defects in material and workmanship for a period of one year from the confirmed date of purchase of the original buyer and that upon written notice of any such defect, Seller will, at its option, repair or replace the defective item under the terms of this warranty, subject to the provisions and specific exclusions listed herein.

This warranty shall not apply to equipment that has been previously repaired or altered outside our plant in any way as to, in the judgment of the manufacturer, affect its reliability. Nor will it apply if the equipment has been used in a manner exceeding its specifications or if the serial number has been removed.

Seller does not assume any liability for consequential damages as a result from our products uses, and in any event our liability shall not exceed the original selling price of the equipment.

The equipment warranty shall constitute the sole and exclusive remedy of any Buyer of Seller equipment and the sole and exclusive liability of the Seller, its successors or assigns, in connection with equipment purchased and in lieu of all other warranties expressed implied or statutory, including, but not limited to, any implied warranty of merchant ability or fitness and all other obligations or liabilities of seller, its successors or assigns.

The equipment must be returned postage-prepaid. Package it securely and insure it. You will be charged for parts and labor if you lack proof of date of purchase, or if the warranty period is expired.