



USER'S MANUAL

**SWITCHING-MODE DC POWER SUPPLY
ARRAY 366XA**

ARRAY ELECTRONIC

ARRAY 366XA SWITCHING-MODE DC POWER SUPPLY

ARRAY 366XA is a series of 500W programmable switching-mode DC power supplies with RS-232, USB (optional) and GPIB (optional) interfaces. The good durability, simple operation, low noise, excellent output accuracy as well as the adjustment from 0V make this series of reliable power supplies the right choice for many applications. It provides flexible and stable DC power for various design and test environments.

Versatile Bench-Top Features

- * High definition liquid crystal display
- * Full-featured keyboard and knobs
- * High-efficient switching-mode power supply
- * The same continuous adjustment (0-Vout) as the linear power supply
- * Low ripple and noise which rivals the linear power supply
- * Excellent line and load regulation
- * Up to 10 operating states storage and recall
- * Portable, ruggedized case and flexible system functions
- * Standardized USB interface, optional GPIB and optional USB interface
- * SCPI (Standard Commands for Programmable Instruments) compatibility
- * Direct setting of I/O Parameters from front-panel

The Front Panel at a Glance

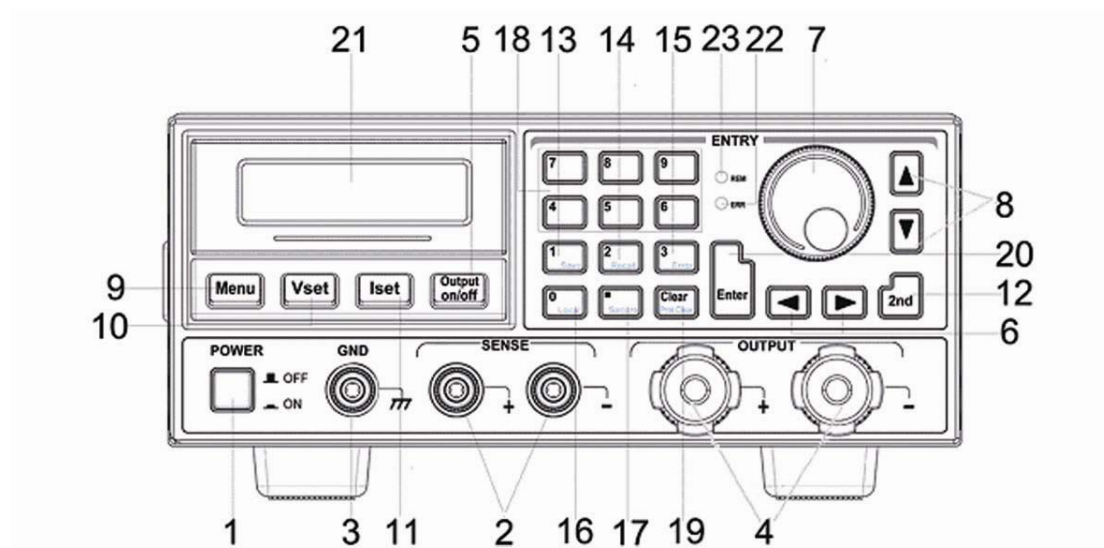

- | | |
|------------------------------------|------------------------------------|
| 1. AC power switch | 2. Sense terminals |
| 3. Earth ground terminal | 4. Supply output terminals |
| 5. Output on/off key | 6. Left/Right key |
| 7. Control knob | 8. Up/Down key |
| 9. Menu setting key | 10. Voltage setting key |
| 11. Current setting key | 12. Switch key for second function |
| 13. Store key for second function | 14. Recall key for second function |
| 15. Error key for second function | 16. Local key for second function |
| 17. Secure key for second function | 18. Number key |
| 19. Clear key for second function | 20. Enter key |
| 21. Display screen | 22. ERR annunciator |
| 23. REM annunciator | |

1. AC power switch: Turns the AC power on and off.
2. Sense terminals: Tests remote voltage, the positive pole is in red, the negative pole is in black.
3. Earth ground terminal: It is connected to the chassis and earth ground.
4. Supply output terminals: Supply output, the positive output terminal is in red, the negative output terminal is in black.
5. Output on/off key: Turns the power supply on/off.
6. Left/Right key: Moves the blinking digit to left or right, or selects different options.
7. Control knob: Adjusts the value of the blinking digit or selects different options by turning clockwise or counter clockwise.
8. Up/Down key: Turns the menu page.
9. Menu setting key: Enters menu setting contents.
10. Voltage setting key (VSET): Displays or modifies the present voltage setting value.
11. Current setting key (ISET): Displays or modifies the present current setting value.

12. Switch key for second function (2nd): Enables the second function of other keys.
13. Store key for second function (Save): Stores the present operating states in location “0”, “1”, ... “9”.
14. Recall key for second function (Recall): Recalls a previously stored operating state from location “0”, “1”,...“9”.
15. Error key for second function (Error): Checks or reads the error codes.
16. Local key for second function (Local): Returns the power supply to local mode from remote control mode.
17. Secure key for second function (I/O config): Secures and unsecures the power supply for calibration.
18. Number key (0-9 and.): Sets values.
19. Clear key for second function (Clear): Clears present input value or exits current operation.
20. Enter key (Enter): Confirms present setting values or option.
21. Display screen: Shows parameters and status of power supply.
22. ERR annunciator: When some error is detected, ERR annunciator is on.
23. REM annunciator: When the power supply is in remote control mode, REM annunciator is on.

Front-Panel Display Messages

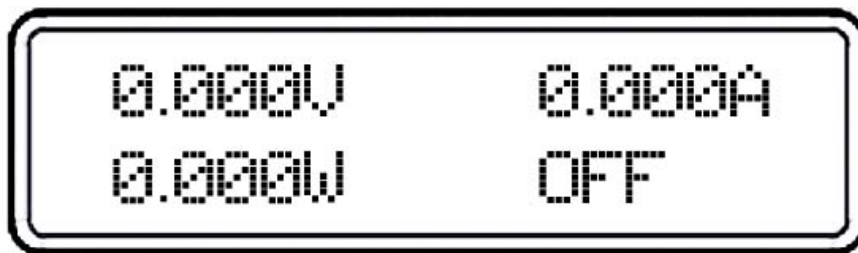

- | | |
|---------------|---|
| 0.000V | Display present voltage value. |
| 0.000A | Display present current value. |
| 0.000W | Display present power value. |
| OT | The power supply is in over-temperature state. |
| OV | The power supply is in over-voltage state and the supply output is disabled. |
| OFF | The output of power supply is off. |
|
 | |
| ERROR | Hardware or remote interface control commands errors are detected and the error bits have not been cleared or read. |
|
 | |
| Unreg | The present output of the power supply is unregulated. (The output is neither CV nor CC.) |
| CV | The output of power supply is in CV mode. |
| CC | The output of power supply is in CC mode. |

The Rear Panel at a Glance

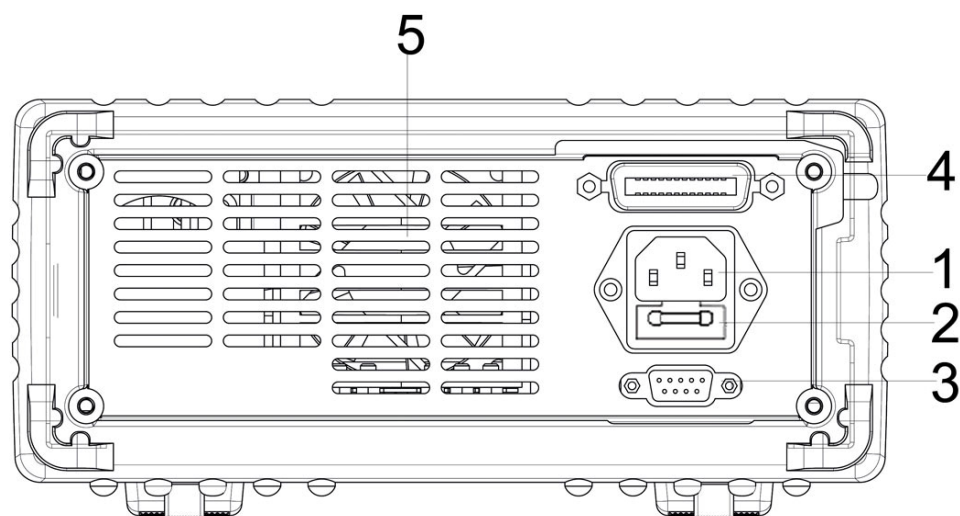

- | | |
|-------------------------------|---|
| 1. AC inlet | 2. Fuse holder |
| 3. RS-232 interface connector | 4. GPIB or USB interface connector (optional) |
| 5. Fan outlet | |

An Introduction to this Manual

General Information

Apart from a general description of your power supply, it provides instructions for checking your power supply, selecting power-line voltage and connecting to AC power.

Initial Operation

It ensures that the power supply develops its rated outputs and responds to operation from the front panel properly.

Front-Panel Operation

It describes the use of front-panel keys and knobs in detail and how to use them to

operate the power supply from the front panel. And it also shows how to configure the power supply for the remote interface and introduces the calibration features in brief.

Remote Interface Reference

It contains the reference information to help you program the power supply over the remote interface, and explains how to program for status reporting as well.

Application Programs

It provides some remote interface applications to help you develop programs for your application.

Tutorial

It describes basic operation of the power supply and gives specific details on the operation and use of ARRAY 366XA power supplies.

Specifications

It lists the power supply's basic specifications.

Contents

Chapter 1 General Information	11
General Information.....	11
Safety Considerations.....	11
Description.....	11
Installation.....	12
Initial Inspection.....	12
Mechanical Check.....	12
Electrical Check.....	12
Temperature Control.....	12
Rack Mounting.....	13
Chapter 2 Initial Operation	14
Initial Operation	14
Preliminary Checkout.....	14
Power-Line Cord.....	14
Fuse Replacement.....	15
Power-On Checkout.....	15
Self-test started.....	15
Self-test accomplished.....	15
Enabling the outputs.....	15
Output Checkout.....	16
Voltage Output Checkout.....	16
Current Output Checkout.....	17
Chapter 3 Front Panel Operation.....	20
Front Panel Operation.....	20
Front Panel Operation Overview.....	20
Output on/off.....	20
Constant Voltage Output Setting.....	21
Connecting a load to the relevant output terminals.....	21
Turning on the power supply.....	21
Setting desired output voltage.....	21
Setting maximum current.....	21
Enabling the outputs.....	22
Verifying that the power supply is in the constant voltage mode.....	22
Constant Current Output Setting.....	22
Connecting a load to the relevant output terminals.....	22
Turning on the power supply.....	22
Maximum output voltage setting.....	22
Setting the desired output current.....	23
Enabling the outputs.....	23
Verifying that the power supply is in the constant current mode.....	23

Menu Setting	24
Main Menu Description.....	24
Storing and Recalling.....	24
Error Messages Display.....	25
Local/ Remote Operation Switch.....	25
Protection Function.....	26
Abnormal Latched State Clearance.....	26
Over-Voltage.....	26
Over-Temperature.....	26
The Power Supply Calibration.....	27
Calibration Instrument.....	27
Cautions.....	27
Calibration Procedures.....	27
Chapter 4 Remote Interface Reference	31
Remote Interface Reference.....	31
SCPI Command Summary.....	31
An Introduction to the SCPI Language.....	32
Command Format Used in This Manual.....	33
Command Separators.....	34
Using the MIN and MAX Parameters.....	34
Querying Parameter Settings.....	34
SCPI Command Terminators.....	35
SCPI Parameter Types.....	35
Numeric Parameters.....	35
Discrete Parameters.....	35
Boolean Parameters.....	35
String Parameters.....	35
Output Setting and Operation Commands.....	36
Trigger Commands.....	36
System-Related Commands.....	36
Calibration Commands.....	37
Status Reporting Commands.....	37
RS-232 Interface Commands.....	38
Simplified Programming Overview.....	38
Using the APPLY Command.....	38
Using the Low-Level Commands.....	38
Selecting a Trigger Source.....	39
Using the APPLY Command.....	39
Output Setting and Operation Commands.....	40
Measurement Commands.....	40
Output on/off and Tracking Operation Commands.....	41
Output Setting Commands.....	41
Trigger Source Choice.....	43

Bus (Software) Triggering.....	43
Immediate Triggering.....	44
Trigger Commands.....	44
System-Related Commands.....	44
Calibration Commands.....	47
RS-232 Interface Commands.....	48
The SCPI Status Registers.....	48
What is an Event Register?.....	48
What is an Enable Register?.....	49
The Questionable Status Register.....	50
The Standard Event Register.....	51
The Status Byte Register.....	53
Status Reporting Commands.....	53
SCPI Conformance Information.....	55
SCPI Confirmed Commands.....	55
Device-Specific Commands.....	57
Chapter 5 Application Programs.....	58
Application Programs.....	58
RS-232 Operation Using QuickBASIC	58
Chapter 6 Tutorial.....	59
Tutorial.....	59
An Overview of ARRAY 366XA Operation.....	59
Output Characteristics.....	59
Unregulated State.....	60
Unwanted Signals.....	60
Connecting the Load.....	61
Output Isolation.....	61
Multiple Loads.....	61
Considerations.....	62
Capacitive Load.....	62
Inductive Load.....	62
Pulse Load.....	62
Reverse Current Load.....	62
Extending the output.....	62
Reliability.....	63
Chapter 7 Specifications	64
Specifications.....	64
Performance Specifications.....	64
Transient Response Time.....	65
Command Processing Time.....	65
Supplemental Characteristics.....	65

APPENDIX Error Messages	68
Error Messages.....	68
Execution Errors.....	68
Self-Test Errors.....	71
Calibration Errors	72

Chapter 1 General Information

General Information

This chapter provides a general description of your power supply. And it also contains instructions relate to initial inspection, selecting the power-line voltage, and connecting your power supply to AC power.

Safety Considerations

This power supply is a safety instrument with a protective earth terminal. The terminal must be connected to earth ground through a power source with a 3-wire ground receptacle when being connected to AC power supply.

Before installation or operation, please check the power supply and read safety markings and instructions introduced in this manual first. Please see relevant chapters for related specific information about safety operations.

Description

ARRAY 366XA is a series of programmable switching-mode DC power supply with stable voltage and constant current. The excellent line and load regulation, extremely low ripple and noise make it well suited as a high preference power system. 366XA, as a kind of high-efficient switching-mode supply, features wide supply input voltage from 100-240AC, high power factor and a minimum output of 0V.

Output voltage or current can be adjusted independently from front panel, or controlled over RS-232, USB, or GPIB interface. Buttons and knobs on the front panel can be used to adjust voltage and current of a selected output; calibrate again without opening the case when the precision falls down (including change password for calibration); switch the power supply from remote control mode to local mode; set and monitor the power supply over remote interface; monitor the setting and output of power supply via the liquid crystal display in front panel, and all the status indication, error information displayed during working.

When being controlled over remote interface, it can be used both as a listener and a speaker at the same time. The power supply can be set and data can be returned over RS-232, USB, or GPIB interface by an external controller. The following functions can be performed through RS-232, USB, or GPIB interface:

- * Voltage and current setting
- * Voltage and current readback
- * Enable or disable track mode
- * Present and stored status readback
- * Programming syntax error detection
- * Calibration
- * Output on/off
- * System self-test

This power supply is equipped with a liquid crystal display for displaying the output of voltage and current. A 5-digit voltage and a 5-digit current could show the actual or setting value of a selected supply simultaneously. And the liquid crystal display can show the current mode of power supply.

Connections to the power supply's output and to chassis ground are made to binding terminals on the front panel. The Sense terminals can remotely sample the power supply's voltage. The positive and negative terminals of each output can be grounded, or kept a certain voltage with the chassis ground. But voltage between each output and the chassis ground should be kept within ± 240 Vdc. The power supply is provided with a detachable 3-wire grounding type power cord. The AC line fuse is on the rear panel. It can be extracted for replacement when needed.

The power supply can be calibrated from the front panel directly without opening the cabinet. Correction factors are stored in non-volatile memory. You can guard against unauthorized calibration by using the "Standard" calibration protection function.

Installation

Initial Inspection

When you receive your power supply, please check it for any obvious damage that may have occurred during shipment or resulted from other reasons. If any damage is found, contact the carrier and the Sales Office immediately in order to deal with it in time.

Keep the original packing materials in case the power supply has to be returned to Array for repairing in the future. If you return the power supply for service, please attach a tag identifying the owner and model number. A brief description of the malfunction is also needed.

Mechanical Check

This check confirms that there are no broken keys or knob, and that the cabinet and panel surfaces are free from dents and scratches, and that the display is not scratched or cracked as well.

Electrical Check

Please see Chapter 2 for an initial operation procedure. When successfully completed, it can be convinced that the power supply is operating in accordance with its specifications.

Temperature Control

The power supply's performance will not be affected when operating within the temperature range of 0°C to 40°C, and within the temperature range of 40°C to 55°C,

the over-temperature protection may take effect, depending on the input voltage and output power. A brushless fan is used to cool the power supply by drawing cool air through the two sides and exhausting the heat through the fan outlet on the rear panel.

Sufficient space must be left at the rear and two sides of the cabinet for air circulation when the power supply is installed. Please remove the rubber bumpers for rack mounting.

Rack Mounting

The power supply could be installed in a standard 19-inch rack.

Please remove the rubber bumpers at the front and end of power supply before installing.

Chapter 2 Initial Operation

Initial Operation

This chapter mainly focuses on three basic tests which should be performed before the operation of the power supply: the preliminary checkout, the power-on checkout, and the output checkout. The preliminary checkout is to check if the power supply could run correctly. The power-on test includes a self-test that checks the internal microprocessors and checks if the user are allowed to examine the display at the front panel under the condition of applying power to the supply properly. The output check ensures that the power supply develops its rated outputs and properly responds to operation from the front panel.



In order to make sure the power supply is in accordance with what is required and have a better command of power supply features for later use, it is suggested that both the experienced and the inexperienced users should read this chapter prior to operation

Preliminary Checkout

ARRAY 366XA power supply can be used from a rated 100 V to 240 V single phase AC power source at 47 to 63 Hz. There is an indication below the AC power inlet on the rear panel showing the rated input voltage set for the power supply at the factory.

Power-Line Cord

The power supply is shipped from the factory with a power-line cord that has a plug appropriate for your location. Please contact the nearest ARRAY Sales and Service Office if the wrong power-line cord is included with your power supply. Your power supply is equipped with a 3-wire grounding type power cord with a diameter of 1mm²X3 and the third conductor is the ground lead. The power supply can operate properly only when the power-line cord is plugged into an appropriate receptacle. Do not operate your power supply without adequate cabinet ground connection.

Fuse Replacement

1 Replace the fuse

Step 1: Remove the fuse-holder below AC power inlet.

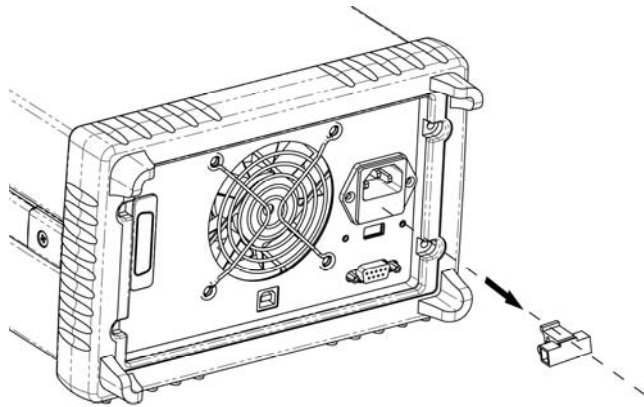

Step 2: Replace the fuse with the correct one that meets the requirements.

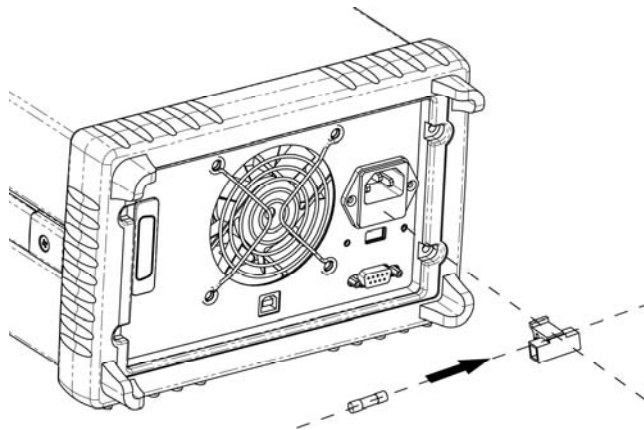

Step 3: Put back the fuse holder.

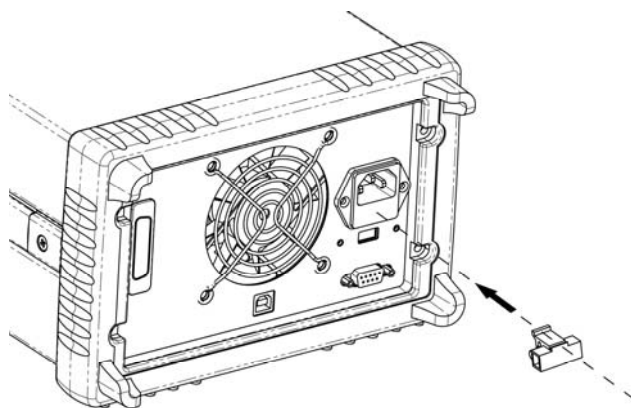

For 115V AC operation, 10AT fuse must be used;
For 230V AC operation, 6AT fuse must be used.

Power-On Checkout

The power-on test includes an automatic self-test that checks the internal microprocessors and a system self-test after the power supply is turned on, and examines the information relate to self-test process shown on the front panel. You will observe the following sequence on the display:

1. Self-test started

 Power It begins with an initial operation immediately after pressing the power switch on. Then self-test starts, involving the test of internal microprocessor and whole power supply system.

2. Self-test accomplished

If there is no error or abnormality has been detected during self testing, the supply will enter into power-on/reset state and the output will be disabled.

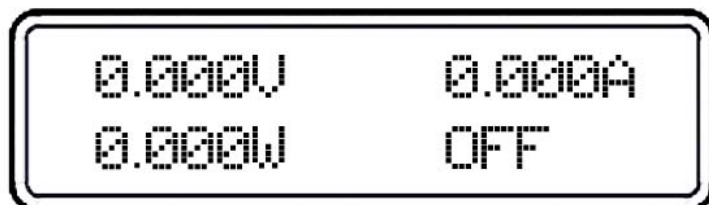

In this figure, “OFF” indicates that supply output is forbidden.

3. Enabling the outputs

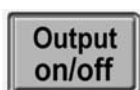

Press “Output on/off” to enable the outputs. The “OFF” annunciator on the lower right corner of the display turns off, while the “ON” and “CV” annunciators at the same place turn on. And the display switches to monitor mode automatically to monitor the actual value of output voltage and current.



If power-on self-test has detected any error or abnormality, the “ERROR” annunciator is lit. For specific information about errors, please see related chapters in appendix.

Output Checkout

The output checkout is to ensure that the power supply develops its rated outputs and properly responds to various operations. Specific steps are shown as followings:

Voltage Output Checkout

1. Turn on the power supply.

Power



■ On
■ Off

Press the “Power-on” button, and finish the power-on checkout. Usually the power supply will go into the power-on / reset state automatically. “OFF” will be shown in the lower right corner of the display and both the output voltage and current are 0.

2. Enable the outputs.

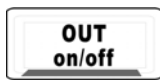

Press the “OUT on/off” button to turn on the power supply outputs. Now the display is in monitor mode; the “CV” or “ON” annunciator in the lower right corner of the display is lit. At the same time a 5-digit voltage meter and a 5-digit current meter are displayed, respectively showing the actual value of output voltage and current of the power supply.

3. Check if the voltmeter properly responds to knob control on front panel for the supply.



Knob Checkout

When the power supply output is on and the display is in monitor mode, move the blinking digit to voltage value displayed by pressing the key “Left”. Turn the knob clockwise or counter clockwise to check that the voltmeter responds to knob control to increase or decrease and the ammeter indicates nearly zero.



Key Checkout

When the power supply output is on and the display is in monitor mode, press key “VSET”, the voltage setting value in the LCD will blink. Press the number keys on front panel directly to set voltage value needed. Then press “Enter” to verify and finish setting and go back to monitor mode. This process is to check that the voltage value displayed responds to the key operation correctly.



- 4 Check if the voltage can be adjusted from zero to the maximum rated value.

Adjust the knob until the voltmeter indicates 0V and then adjust the knob gradually until the voltmeter indicates the maximum rated value with the method explained in last step. At the same time check if the voltmeter and output voltage changes as voltage changes.

Current Output Checkout

Power



■ On
■ Off

1. Turn on the power supply.

Press “Power-on” button and finish the power-on checkout. Usually the power supply will go into the power-on / reset state automatically and the “OFF” annunciator in the lower right corner of the LCD turns on. Both the voltage value and current value are 0.

2. Connect a short across (+) and (-) output terminals of the supply with an insulated test lead. The sectional area of the shorting stub should be larger than 1.5mm².

3. Enable the outputs.

Set the supply voltage to 5V according to the voltage setting measure. Press the “OUT on/off” button, the display is in monitor mode. At the same time a 5-digit voltage meter and a 5-digit current meter are displayed, showing the actual value of output voltage and output current of the power supply respectively. The CV or CC modes depend on the resistance of the test lead.

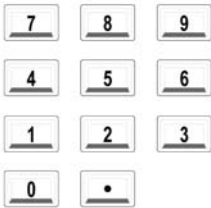
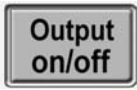

4. Adjust the voltage limit value to 1.0 V.

Adjust the voltage limit to 1.0 V to assure CC operation. Please see related chapters about voltage and current setting from front panel in this manual for specific operations.



5. Check that the front-panel ammeter properly responds to the key and knob operations from the front panel.



Knob Checkout

When the output of the power supply is turned on and the display is in monitor mode, press “Right” key to move the blinking digit to current value displayed, and turn the knob clockwise or counter clockwise to check if the current value displayed increases or decreases as current changes.

Key Checkout

When the output of the power supply is turned on and the display is in monitor state, press “ISET” and the current setting value is blinking. Press the number keys on front panel directly to set current value needed. Then press “ENTER” to verify and finish setting and go back to monitor mode. This process is to check that the current value displayed responds to the key operation correctly.





6. Ensure that the current can be adjusted from 0A to the maximum rated value.

Adjust the knob until the ammeter indicates 0A and then until the ammeter indicates the maximum rated value.



If an error has been detected during the output checkout procedures, the ERROR annunciator will turn on. Refer to the related chapters in appendix for more specific error information.

Chapter 3 Front Panel Operation

Front Panel Operation

3.1 Front Panel Operation Overview

- Output on/off
- Constant Voltage setting
- Constant Current setting
- Menu Setting
- Storing and Recalling
- Error Messages Display
- Local/Remote Operation switch
- Protection Function
- Power Supply Calibration

3.2 Output on/off



The output of the power supply could be switched on or off through this button.

When the output of the power supply is disabled, you can enable it by pressing “Out on/off” key, and it can be turned off by pressing this key again.

When the output of the power supply is enabled, “CV”, “CC” or “Unreg” will be displayed in the lower right corner of the display. “CV” indicates that the supply source is in constant voltage state, “CC” indicates that the power supply is in constant current state and “Unreg” indicates that the power supply is operating in unstable state (Neither in constant voltage nor constant current status).

For example: if the power supply output is in constant voltage state, the actual output voltage is 5V and the actual output current is 3A, the display will show as follows:

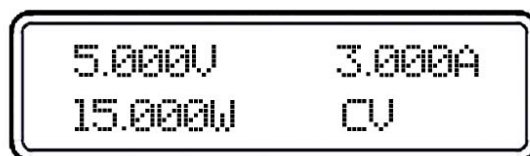

When the output of the power supply is off, the “OFF” annunciator in the lower left corner of the display is lit and the keys as well as the knobs are still valid. Then the display will show as follows:

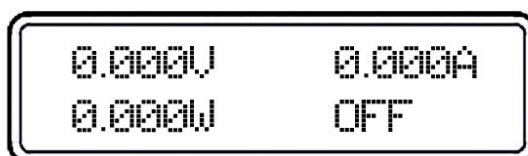

When it is operated from remote interface, inputting the following command can enable or disable the output: OUTPUT ON/OFF. You can turn on the output by selecting ON and turn off the output by selecting OFF.

3.3 Constant Voltage Output Setting

Constant voltage output is the most common output of the power supply. The voltage outputs at a constant value in constant voltage output mode, and it will not change with the load while the current will. The CV annunciator in the lower left corner of the LCD will turn on when the power supply is in constant voltage mode. Then the operation procedures of constant voltage output will be introduced with examples.

1. Connecting a load to the relevant output terminals

Turn off the power supply. Connect the load to the relevant output terminals. Connect the positive pole of the load to “+” terminal of the output, and connect the negative pole to “-” terminal of the output.

2. Turning on the power supply

Press the “Power on/off” button in the front panel. The power supply will go into power-on/ reset state, namely the power supply is off.



3. Setting desired output voltage

The desired output voltage can be set directly by pressing number keys or using “Left/Right” key together with the knob.

1). Using number keys and “Enter” key to input:

- ① Press “Vset” to enter into voltage setting state.
- ② Input the desired voltage value by pressing number keys. “Clear” key can be used to clear the wrong value to input again.
- ③ Press “Enter” key to confirm the voltage setting value.

2). Using “Left/Right” keys, knob and “Enter” key to input:

- ① Press “Vset” to enter into voltage setting state.
- ② Press “Left/Right” keys to move the blinking digit to the relevant digit of the value.
- ③ Increase or decrease the relevant value by turning the knob clockwise or counter clockwise. Then use “Left/Right” keys to move to the next digit to modify.
- ④ Press “Enter” key to confirm the voltage setting value.

4. Setting maximum current

The maximum current can be set directly by pressing the number keys or using “Left/Right” keys together with the knob.

1). Using number keys and “Enter” key to input:

- ① Press “Iset” key to enter into current setting state.

② Input the desired current value by pressing number keys. “Clear” key can be used to clear the wrong value to input again.

③ Press “Enter” key to confirm the current setting value.

2). Using “Left/Right” keys, knob and “Enter” key to input:

① Press “Iset” key to enter into current setting state.

② Press “Left/Right” keys to move the blinking digit to the relevant digit of the value.

③ Increase or decrease the relevant value by turning the knob clockwise or counterclockwise, then use “Left/Right” keys to move to the next digit to modify.

④ Press “Enter” key to confirm the current setting value.

5. Enabling the outputs

Press the “Output on/off” key to enable the outputs. “CV” is displayed in the lower right corner of the display.

6. Verifying that the power supply is in the constant voltage mode

When you operate the power supply in the constant voltage (CV) mode, if “CC” is displayed in the lower left corner of the display, it indicates that the actual output current value has reached our setting value. Therefore please choose a higher current limit value.

3.4 Constant Current Output Setting

When the power supply is in constant current mode, the current will output at a constant value, and it will not change with the load while the voltage will. The CC annunciator in the lower right corner of the display will turn on when the power supply is in constant current mode. The operation methods of constant current output are introduced in the following.

1. Connecting a load to the relevant output terminals

Turn off the power supply. Connect the load to the relevant terminals. Connect the positive pole of the load to “+” terminal of the output, and connect the negative pole to “-” terminal of the output.

2. Turning on the power supply

Press the “Power on/off” button in the front panel. The power supply will go into power-on/ reset state, namely the power supply is off.

3. Maximum output voltage setting

Maximum output voltage can be set directly by pressing number keys or using “Left/Right” key together with the knob.

1). Using number keys and “Enter” key to input:

① Press “Vset” to enter into voltage setting state.

② Input the desired voltage value by pressing number keys. “Clear” key can be used to clear the wrong value to input again.

③ Press “Enter” key to confirm the voltage setting value.

2). Using “Left/Right” keys, knob and “Enter” key to input:

① Press “Vset” to enter into voltage setting state.

- ② Press “Left/Right” keys to move the blinking digit to the corresponding digit of the value.
- ③ Increase or decrease the relevant value by turning the knob clockwise or counter clockwise, then use “Left/Right” keys to move to the next digit to modify.
- ④ Press “Enter” key to confirm the voltage setting value.

4. Setting the desired output current

The desired current can be set directly by pressing the number keys or using “Left/Right” keys together with the knob.

1). Using number keys and “Enter” key to input:

- ① Press “Iset” to enter into current setting state.
- ② Input the desired current value by pressing number keys. “Clear” key can be used to clear the wrong value to input again.
- ③ Press “Enter” key to confirm the current setting value.

2). Using “Left/Right” keys, knob and “Enter” key to input:

- ① Press “Iset” to enter into current setting state.
- ② Press “Left/Right” keys to move the blinking digit to the corresponding digit of the value.
- ③ Increase or decrease the relevant value by turning the knob clockwise or counter clockwise, then use “Left/Right” keys to move to the next digit to modify.
- ④ Press “Enter” key to confirm the current setting value.

5. Enabling the outputs.

Press the “Output on/off” key to enable the outputs. “CC” is displayed in the lower left corner of the display.

6. Verifying that the power supply is in the constant current mode

When the power supply is operating in the constant current mode, if the “CV” is displayed in the lower left corner of the display, it indicates that the actual output voltage value has reached our setting value. Therefore please choose a higher voltage limit.

3.4 Menu Setting

3.4.1 Main Menu Description

Press “Menu” key to enter into main menu, which is showed as follows:

Function and Parameter		Description
Current Limit: 14.600A		Current Limit: Current Limit Value
Voltage Limit: 35.200V		Voltage Limit: Voltage Limit Value
Voltage Over: 36.000V		Voltage Over: Over Voltage Value
Beep: *On Off		Beep: On Off
Knob: *On Off		Knob: On Off
Interface: *RS232 USB GPIB		Interface Choices: RS232 USB GPIB
RS232 Interface	Baud Rate 4800 *9600	Baud Rate Setting 300 600 1200 2400 4800 9600 19200 38400
	Parity Check *None Even Odd	Parity Check None Even Odd
	Data Bit: 5 6 7 *8	Data Bit: 5 6 7 *8
	Stop Bit: *1 2	Stop Bit: *1 2
	Flow Control: *On Off	Flow Control: *On Off
USB Interface		Selecting USB
GPIB Interface	GPIB Address: 5	GPIB Address: Address Value

Notes: Except the parameters about knob, key sound and interface configuration, other parameters in the main menu will not be saved when the power supply is switched off. If you would like to store relevant parameters, please press “2nd” + “Save” keys or make use of *sav command.

3.6 Storing and Recalling

Store and recall procedures are illustrated in the following:

- 1 Press “2nd” + “Save” keys to enter into electronic store menu, or press “2nd” + “Recall” keys to enter into electronic recall menu
- 2 Press keys or adjust the knob to select store or recall location (0~9).
- 3 Press “Enter” key to confirm and exit store or recall menu simultaneously. For a store case, voltage and current values are saved in corresponding EEPROM and for a

recall condition, the voltage and current values stored previously can be retrieved from corresponding EEPROM and set as present values.

Example 1: Set voltage to 5V and current to 2A. Then turn on the power supply and save this state to the EEPROM specified by Location 1.

Step	Operational Details	Display Information
1	Set voltage to 5V and current to 2A. Then turn on the power supply.	5.000V 2.000A 0.000W CV
2	Press “2nd” + “Save” keys to enter into store menu.	Save: 0
3	Press keys or adjust the knob to select store location as 1.	Save: 1
4	Press “Enter” key to confirm and exit store menu simultaneously.	5.000V 2.000A 0.000W CV

Example 2: Based on Example 1, set voltage to 30V. Then turn off the power supply and recall the values saved in the EEPROM specified by Location 1.

Step	Operational Details	Display Information
1	Set voltage to 30V. Then turn off the power supply.	30.000V 0.000A 0.000W OFF
2	Press “2nd” + “Recall” keys to enter into recall menu.	Recall: 0
3	Press keys or adjust the knob to select recall location as 1.	Recall: 1
4	Press “Enter” key to confirm and exit recall menu simultaneously.	5.000V 2.000A 0.000W CV

3.7 Error Messages Display

If some error has been detected, “err” annunciator will be lit. Then you can read the error messages through front panel operation with following steps:

1 Press “2nd” + “Error” keys and the display will show the error messages.

Example 1: if there is a wrong command, “err” annunciator will turn on. Then check the error messages with following steps:

Step	Operational Details	Display Information
1	Press “2nd” + “Error” keys and the display will show the error messages.	ERROR -103
2	If some error has been detected, repeat the first step.	
3	When there is no error, “err” annunciator will be off. Repeat the first step, then “NO ERROR” will be showed in the display.	NO ERROR

3.8 Local/ Remote Operation Switch

If it is need to operate the power supply from the keys and knobs in the front panel, the power supply must keep in local control state. And the power supply will stay in

this state as soon as it is switched on.

In remote control state, all keys and knobs become invalid (except “2nd” and “Local” keys). When the power supply receives the remote command (SYST:REM) through RS232 Interface or commands through GPIB Interface, REM annunciator will be on and remote control becomes valid. In remote control state, all operations of the power source are controlled by remote controller. After receiving the command demanding the power supply to return to local control (eg. SYST:LOC), the power supply will go back to local control state and REM annunciator will be off. In remote control state, the power supply can be returned to local control state by pressing “2nd” + “Local” keys even if it has not received the returning command.

3.9 Protection Function

There are two protection states: over-voltage protection and over-temperature protection for 3662A. Once anything abnormal is detected, the corresponding state symbol in the State Register will be set; the power supply will disable its output and beep to give an alarm; the display reveals the reason for the unusual condition and the power supply enters into abnormal latched state. Except specific operations, the supply will stop responding to other commands. For example: when the temperature is too high, supply output will turn off and beep to give an alarm. OT will be showed in the lower right corner of the display and the power supply will not respond to other commands.

3.9.1 Abnormal Latched State Clearance

When the power supply enters into abnormal latched state, it fails to respond to other commands. Only when the abnormal latched state is cleared by pressing “2nd” + “Clear” keys, can normal operations be restored. Obviously, the reason for the abnormal latch must be solved, or the power supply will enter into abnormal latched state once again immediately.

3.9.2 Over-Voltage

The user can set the over-voltage protection value (Voltage Over) in the menu as needed. When supply output voltage is higher than the set value, the system enters into over-voltage protection status and the display shows OV. This state can be cleared by decreasing the output voltage or increasing the over-voltage protection value. Otherwise, even though you can remove the latched state by pressing “2nd” + “Clear” keys, the system will automatically enter over-voltage protection status once again for over-voltage.

3.9.3 Over-Temperature

If the internal temperature of the supply is above the safety limitation, over-temperature protection will be triggered; the supply output will turn off and OT is displayed. In the meantime, OT and PS in the Questionable Status Register will be set and keep in this state until they are reset and over-temperature state is removed. You can't clear the abnormal latched state until the supply temperature falls to its

normal range.

The Power Supply Calibration

Because various factors may cause the reduction of the power supply's output precision after it has been used for a period of time, the user should calibrate the power supply's output to make the output return to the previous precision. But it is suggested that the power should not be calibrated frequently. This section mainly introduces how to unsecure the power supply and the detailed procedures of manual calibration.

Calibration Instrument

Multimeter (DVM)

FLUKE 45: measures the DC current

KEITHLEY 2000: measures the DC voltage

Power supply: CHROMA 61601 AC power supply

Cautions

- When the calibration is conducted, the ambient temperature should be within the range of $25^{\circ}\text{C} \pm 2^{\circ}\text{C}$. All testing instruments and the supply power must be preheated for 30 minutes before the calibration.
- As when the FLUKE 45 measures a current as high as 9.5A, the sample resistance temperature will increase and give rise to a change in resistance value, you should test the high current as soon as possible.

Calibration Procedures

Press the "Vset" key and the display will show as follows:

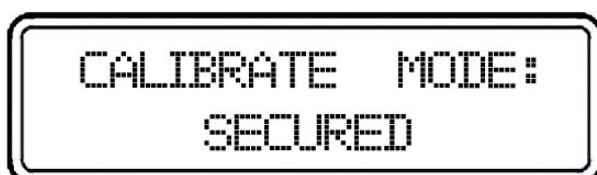

```
CALIBRATE  MODE:
          SECURED
```

Press "secure" key after pressing "2nd" key and you will see the following graph:



```
INPUT  PASSWORD
          —
```

Input the password "003662", then press "Enter" key to enter into calibration menu, which is shown as below:

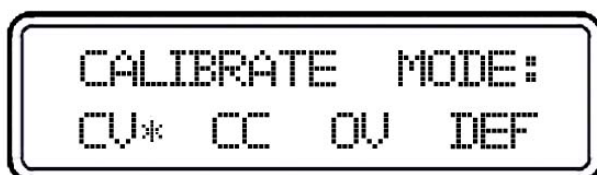

```
CALIBRATE  MODE:
CV*  CC  OV  DEF
```

Select CV, CC or OV mode calibration by direction key. If “DEF” is selected, all calibration parameters are restored to default value. CV, CC and OV mode should be calibrated one by one, which is the correct calibration sequence. Return to calibration menu after each mode calibration is completed. Press “Clear” key to exist calibration state.

3.1 CV Mode Calibration

In this mode, three voltage points: 0.5V、22V、34.5V should be calibrated.

3.1.1 Wiring

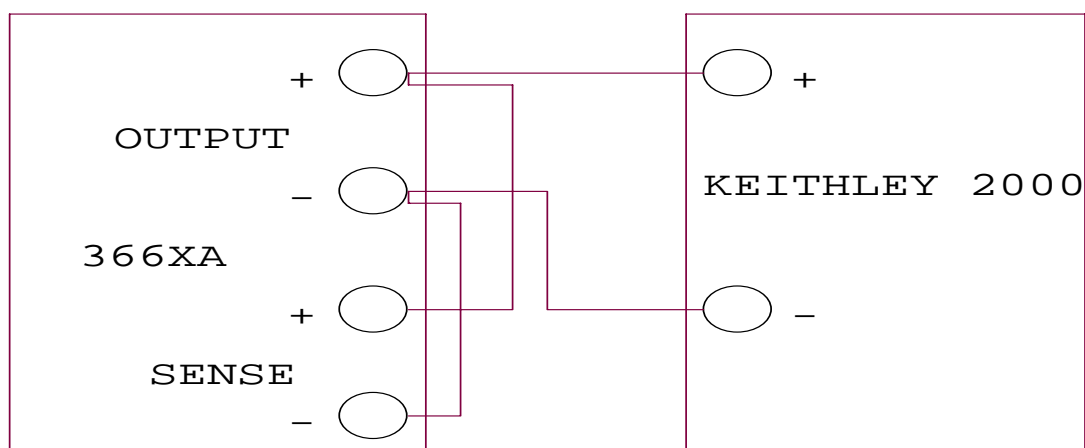

3.1.2 0.5V Calibration

Press “Enter” key, you will see the following figure in the display:



Input the value you read from KEITHLEY 2000, which is retained to four decimal places. Press “Clear” key to remove the wrong input value of current digit. Then press “Enter” key to confirm.

3.1.3 22 V Calibration

Press “Enter” key to verify and then you will see the followings:



Input the value you read from KEITHLEY 2000, which is retained to four decimal places. Press “Clear” key to remove the wrong input value of current digit. Then press

“Enter” key to confirm.

3.1.4 34.5V Calibration

Press “Enter” key to verify and then the display will show as follows:



Input the value you read from KEITHLEY 2000, which is retained to four decimal places. Press “Clear” key to remove the wrong input value of current digit. Then press “Enter” key to confirm and exit to calibration menu. Now, voltage calibration is completed.

3.2 CC Mode Calibration

In this mode, three current points: 0.5A, 6A, 9A should be calibrated.

3.2.1 Wiring

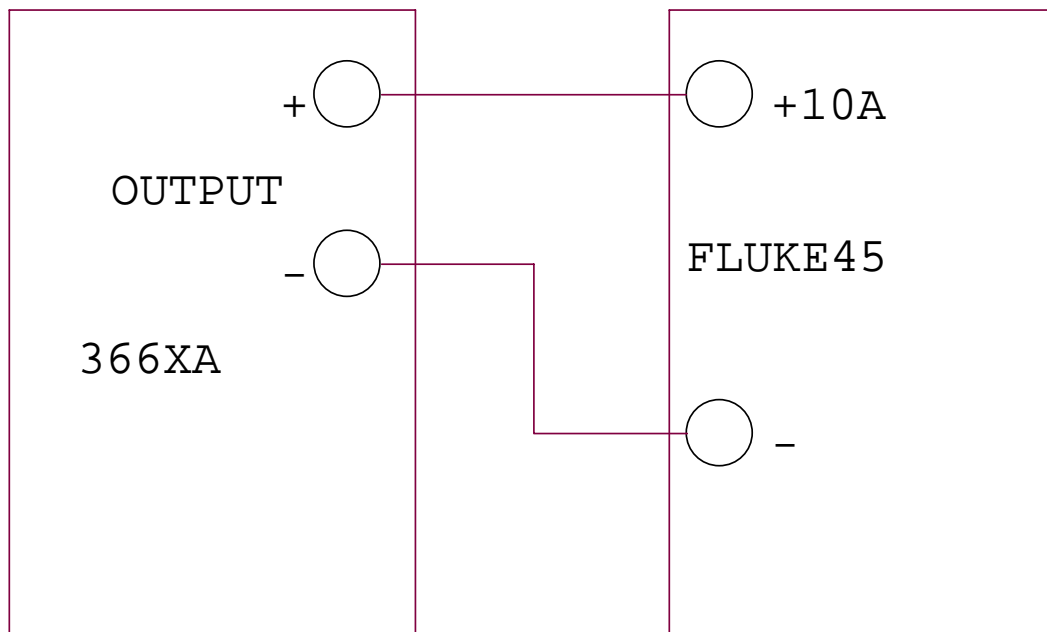

3.2.2 0.5A Calibration

Press “Enter” key, you will see the following figure in the display:



Input the value you read from FLUEK 45, which is retained to four decimal places. Press “Clear” key to remove the wrong input value of present digit. Then press “Enter” key to confirm.

3.2.3 6A Calibration

Press “Enter” key to verify and then you will see the followings:



Input the value you read from FLUEK 45, which is retained to four decimal places. Press “Clear” key to remove the wrong input value of present digit. Then press “Enter” key to confirm.

3.2.4 9A Calibration

Press “Enter” key to verify and then the display will show as follows:



Input the value you read from FLUEK 45, which is retained to four decimal places. Press “Clear” key to remove the wrong input value of present digit. Then press “Enter” key to confirm.

3.3 OV Calibration

OV calibration is a kind of automatic calibration without manual operation, which starts after the voltage calibration is conducted and is shown in the following:



When the calibration is completed, the display will go back to the calibration menu.

Chapter 4 Remote Interface Reference

Remote Interface Reference

A detailed description of how to use the remote interface will be given in this chapter, which includes how to program the power supply through the remote interface, the commands format and matters need attention.

- SCPI Command Summary
- Simplified Programming Overview
- Using the Apply Command
- Output Setting and Operation Commands
- Triggering Commands
- System-Related Commands,
- Calibration Commands
- RS-232 Interface Commands
- The SCPI Status Registers
- Status Reporting Commands
- An Introduction to the SCPI Language
- Halting an Output in Progress
- SCPI Conformance Information



If this is the first time you use the SCPI language, it is suggested intensely to read this chapter attentively in order to become familiar with the language before you attempt to program the power supply.

SCPI Command Summary

This section mainly introduces the SCPI (Standard Commands for Programmable Instruments) commands available to program the power supply. Refer to the later sections in this chapter for more complete details on the format and function of each command.

Each SCPI command presented in this section uses the following conventional format.

1. Square brackets ([]) indicate optional keywords or parameters.
2. Braces ({ }) enclose parameters within a command string.
3. Triangle brackets (< >) indicate that you must substitute a value or a code for the enclosed parameter.
4. A vertical bar (|) separates one of two or more alternative parameters.

An Introduction to the SCPI Language

SCPI (Standard Commands for Programmable Instruments) is an ASCII-based instrument command language designed for test and measurement instruments.

The detailed techniques used to program the power supply over the remote interface are introduced in the following sections.

SCPI commands are based on a hierarchical structure, also known as a tree system. In this system, associated commands are grouped together under a common node or root, thus forming subsystems. A portion of the SOURce subsystem is shown below to illustrate the tree system.

```
[SOURce:]
  CURRent
    [:LEVel]
      [:IMMediate]
        [:AMPLitude] {<current>|MIN|MAX}
        [:AMPLitude]? [MIN|MAX]
      :TRIGgered
        [:AMPLitude] {<current>|MIN|MAX}
        [:AMPLitude]? [MIN|MAX]
    :LIMit
      [:AMPLitude] {<current>|MIN|MAX}
      [:AMPLitude]? [MIN|MAX]
  VOLTage
    [:LEVel]
      [:IMMediate]
        [:AMPLitude] {<voltage>|MIN|MAX}
        [:AMPLitude]? [MIN|MAX]
      :TRIGgered
        [:AMPLitude] {<voltage>|MIN|MAX}
        [:AMPLitude]? [MIN|MAX]
    :LIMit
      [:AMPLitude] {<voltage>|MIN|MAX}
      [:AMPLitude]? [MIN|MAX]
```

[SOURce:] is the root keyword of the command, CURRent and VOLTage are the second-level keywords, and LIMit is the third-level keywords. A colon (:) separates a command keyword from a lower-level keyword.

Command Format Used in This Manual

The format used to show commands in this manual is shown below:

```
CURRent { <current>|MINimum|MAXimum }
```

The command syntax shows most commands are the mixture of upper- and lower-case letters. The upper-case letters indicate the abbreviated spelling for the command. For shorter program lines, send the abbreviated form. For better program readability, send the long form. But notice that only the complete spelling form and the upper-case letters are acceptable for the keyword. Give the following example to illustrate:

In the above syntax statement, CURR and CURRENT are both acceptable forms for the keyword “CURRent”. As you can use the mixture of upper- or lower-case letters for the commands, CURR, Curr, and CURr are all acceptable. Notice that the upper-case letters are indispensable. For example, “CUR” is incorrect. And “CURRe”, “CURRen”, will generate an error because of the incomplete spelling.

Braces “{ }” enclose the parameter choices for a given command string. The braces are not sent with the command string.

A vertical bar “|” separates multiple parameter choices for a given command string.

Triangle brackets “< >” indicate that you must specify a value for the enclosed parameter. For example, the above syntax statement shows the current parameter enclosed in triangle brackets. You must specify a value for the current parameter, which is not enclosed in the triangle bracket (such as “CURR 0.1”).

Some parameters are enclosed in square brackets “[]”. The brackets indicate that the parameter is optional and can be omitted. The brackets are not sent with the command string. If you do not specify a value for an optional parameter, a default value will be chosen by power supply.

A colon “:” separates a command keyword from a lower-level keyword. You must insert a blank space to separate a parameter from a command keyword. If a command requires more than one parameter, you must separate adjacent parameters with a comma as shown below:

```
SOURce:CURRent:TRIGgered  
APPL 3.5,1.5
```

Command Separators

A colon “ : ” is used to separate a command keyword from a lower-level keyword as shown below:

```
SOURce:CURRent:TRIGgered
```

A semicolon “ ; ” is used to separate two commands within the same subsystem as shown below:

```
SOUR:VOLT MIN;CURR MAX
```

The following two commands have the same effect as the above command.

```
SOUR:VOLT MIN  
SOUR:CURR MAX
```

Use a colon and a semicolon to link commands from different subsystems. For example, in the following command string, an error is generated if you do not use the colon and semicolon:

```
MEAS:VOLT?;:SOUR:CURR MIN
```

Using the MIN and MAX Parameters

You can substitute MINimum or MAXimum for the parameter of many commands. For example, consider the following command:

```
CURRent { <current>|MIN|MAX }
```

Instead of selecting a specific current, you can substitute MINimum to set the current to its minimum value or MAXimum to set the current to its maximum value.

Querying Parameter Settings

You can query the value of most parameters by adding a question mark (?) to the command. For example, the following command sets the output current to 5A

```
CURR 5
```

You can query the value by executing:

```
CURR?
```

You can also query the minimum or maximum value allowed with the present function as follows:

```
CURR? MAX  
CURR? MIN
```

SCPI Command Terminators

A command string sent to the power supply must terminate with a <new line> character. The IEEE-488 EOI (end-or-identify) message is interpreted as a <new line> character and can be used to terminate a command string in place of a <new line> character. A <carriage return> followed by a <new line> is also accepted.

SCPI Parameter Types

The SCPI language defines several different data formats to be used in program messages and response messages.

Numeric Parameters: Commands that require numeric parameters will accept all commonly used decimal representations of numbers including optional signs, decimal points, and scientific notation. Special values for numeric parameters like MINimum, MAXimum, and DEFault are also accepted. You can also send engineering unit suffixes (V, A or SEC) with numeric parameters. If only specific numeric values are accepted, the power supply will automatically round the input numeric parameters. The following command uses a numeric parameter:

```
CURR {<current>|MINimum|MAXimum}
```

Discrete Parameters: Discrete parameters are used to program settings that have a limited number of values (like BUS, IMM). Query responses will always return the short form in all upper-case letters. The following command uses discrete parameters:

```
TRIG:SOUR {BUS|IMM}
```

Boolean Parameters: Boolean parameters represent a single binary condition that is either true or false. For a false condition, the power supply will accept “OFF” or “0”. For a true condition, the power supply will accept “ON” or “1”. When you query a boolean setting, the power supply will always return “0” or “1”. The following command uses a boolean parameter:

```
DISP {OFF|ON}
```

String Parameters: String parameters can contain virtually any set of ASCII characters. A string must begin and end with matching quotes; either with a single quote or with a

double quote. You can include the quote delimiter as part of the string by typing it twice without any characters in between. The following command uses a string parameter:

```
DISPlay:TEXT <quoted string>
```

Output Setting and Operation Commands

```
APPLy [{<voltage>|DEF|MIN|MAX}][,{<current>|DEF|MIN|MAX}]]
```

```
APPLy?
```

```
MEASure
```

```
  :CURRent[:DC]?
```

```
  [:VOLTagE][:DC]?
```

```
Output
```

```
  [:STATe] {OFF|ON}
```

```
  [:STATe]?
```

```
  :TRACk[:STATe] {OFF|ON}
```

```
:   TRACK[:STATe]?
```

```
[SOURce:]
```

```
  CURRent[:LEVel][:IMMEDIATE][:AMPLitude] {<current>[MIN|MAX]}
```

```
  CURRent[:LEVel][:IMMEDIATE][:AMPLitude]? [MIN|MAX]
```

```
  CURRent[:LEVel]:LIMit[:AMPLitude] {<current>[MIN|MAX|DEF]}
```

```
  CURRent[:LEVel]:LIMit[:AMPLitude]? {MIN|MAX|DEF}
```

```
  CURRent[:LEVel]:TRIGgered[:AMPLitude] {<current>[MIN|MAX]}
```

```
  CURRent[:LEVel]:TRIGgered[:AMPLitude]? [MIN|MAX]
```

```
  VOLTagE[:LEVel][:IMMEDIATE][:AMPLitude] {<current>[MIN|MAX]}
```

```
  VOLTagE[:LEVel][:IMMEDIATE][:AMPLitude]? [MIN|MAX]
```

```
  VOLTagE[:LEVel]:LIMit[:AMPLitude] {<current>[MIN|MAX|DEF]}
```

```
  VOLTagE[:LEVel]:LIMit[:AMPLitude]? {MIN|MAX|DEF}
```

```
  VOLTagE[:LEVel]:TRIGgered[:AMPLitude] {<current>[MIN|MAX]}
```

```
  VOLTagE[:LEVel]:TRIGgered[:AMPLitude]? [MIN|MAX]
```

Trigger Commands

```
INITiate[:IMMEDIATE]
```

```
TRIGger[:SEQUENCE]
```

```
  :DELay {<second>[MIN|MAX]}
```

```
  :DELay?
```

```
  :SOURce {BUS|IMM}
```

```
  :SOURce?
```

```
*TRG
```

System-Related Commands

```
DISPlay[:WINDow]
```

[:STATe] {OFF|ON}
[:STATe]?
:TEXT[:DATA] <quoted string >
:TEXT[:DATA]?
:TEXT:CLEar

SYSTem

:BEEPer[:IMMediate]
:ERRor?
:VERSion?

*IDN?

*RST

*TST?

*SAV {1|2|3}

*RCL {1|2|3}

Calibration Commands

CALibration

:COUNT?
:CURRent[:DATA] < numeric value >
:CURRent:LEVel {MIN|MAX}
:SECure:CODE <new code >
:SECure:STATe {OFF|ON},<new code>
:SECure:STATe?

:STRing <quoted string >
:STRing?

:VOLTage[:DATA] < numeric value >
:VOLTage:LEVel {MIN|MAX}

Status Reporting Commands

STATus:QUEStionable

[:EVENT]?
:ENABle <enable value >
:ENABle?
:INSTrument[:EVENT]?
:INSTrument:ENABle <enable value>
:INSTrument:ENABle?
:INSTrument:ISUMmary<n>[:EVENT]?
:INSTrument:ISUMmary<n>:CONDition?
:INSTrument:ISUMmary<n>:ENABle <enable value>
:INSTrument:ISUMmary<n>:ENABle?

SYSTem:ERRor?
*CLS
*ESE <enable value>
*ESE?
*ESR?
*OPC
*OPC?
*PSC {0|1}
*PSC?
*SRE <enable value>
*SRE?
*STB?
*WAI

RS-232 Interface Commands

SYSTem
 :LOCal
 :REMote
 :RWLock

Simplified Programming Overview

This chapter gives an overview of the basic commands used to program the power supply over the remote interface. Some of them are the SCPI-confirmed commands, and some are the device-specific commands. It is unnecessary to differentiate them when using ARRAY 366XA.

Using the APPLy Command

The APPLy command provides the most straightforward method to program the power supply over the remote interface, such as to control one output or triple outputs of power supply, and to read the immediate output value of each supply. Give the following example to illustrate:

APPLY 3.3,2.0 Set the supply to an output of 3.3V rated at 2.0A

APPLY 12.0,0.5 Set the supply to an output of 12.0V rated at 0.5A

Using the Low-Level Commands

The main feature of the low-level commands is to provide you with more flexibility to change or query the individual parameters than the APPLy command. Give the following example to illustrate how to use the low-level commands to set the supply to an output of 5.0V rated at 4.0A:

VOLT 3.3

CURR 2.0

The two commands shown in this example has the same function as the first command shown in the above example, which shows when some individual parameter is changed, there is no need to enter the whole setting parameters as the above example, just enter some specified parameter.

Reading a Query Response

Only the query commands (commands that end with “?”) will instruct the power supply to send a response message, which gives the either returned values or internal instrument settings. Take below commands as examples to illustrate:

SYST:ERR? Query and read the error message, and return a relevant error message

CAL:SEC:STAT? Query the calibration security, and return the relevant value

SYST:VERS? Query the system version, and return the version number accordingly

Selecting a Trigger Source

The power supply will accept a “bus” (software) trigger or an immediate internal trigger as a trigger source. By default, the “bus” trigger source is selected. If you want the power supply to use an immediate internal trigger, you must select “IMMediate”. For example:

TRIG:SOUR IMM Select an immediate internal trigger as a trigger source

INIT Initiate the trigger system

Using the APPLY Command

APPLy

{<voltage>|DEF|MIN|MAX}[,{<current>|DEF|MIN|MAX}]

This command is to specify the power supply’s output, which can be divided into three parts:

The first part is the keyword “APPLy”.

The second part is to set the voltage value $\{<voltage>|DEF|MIN|MAX\}$, by which you can set the output voltage value of the specified supply. For the setting range, please consult the relevant voltage parameters listed in the table of “Programming Ranges and Output Identifiers” section.

The third part is to set the current value $\{<current>|DEF|MIN|MAX\}$, by which you

can set the output current value of the specified supply. For the setting range, please consult the relevant current parameters listed in the table of “Programming Ranges and Output Identifiers” section.

When the voltage and current are set, the “*DEF/MIN/MAX*” represents the default value, the minimum value and the maximum value respectively.

For example:

APPLY 5.0,2.5 Set the supply to an output of 5.0V rated at 2.5A



Executing the low-level commands has the same effect as this command. Please refer to the last section.

APPLY?

This command queries and returns the power supply’s present voltage and current values for each output. For example:

APPLY? Query and return the voltage and the current set values of power supply.

Output Setting and Operation Commands

This section describes the low-level commands used to program the output of power supply. Although the APPLY command provides the most straightforward method to program the output of power supply, the low-level commands give you more flexibility to change individual parameters, which include output selection commands, measurement commands, output on/off and tracking operation commands and output setting commands.

Measurement Commands

MEASure:CURRENT[:DC]?

This command measures and returns the current value at the present output terminals of the power supply. The physical outputs of measurement are specified by the output identifier. If any output identifier is not specified, the current of the selected output is returned.

MEASure:VOLTage[:DC]?

This command measures and returns the voltage value at the present output terminals of the power supply. The physical outputs of measurement are specified by the output identifier. If any output identifier is not specified, the voltage of the currently selected output is returned.

Output on/off and Tracking Operation Commands

Output[:STATe] {OFF|ON}

This command enables or disables the outputs of the power supply.

For example:

OUTPUT ON	Enable the outputs
OUTPUT OFF	Disable the outputs

Output[:STATe]?

This command queries the output state of the power supply and returns the corresponding values. “OFF” shows the output is disabled, and “ON” shows the output is enabled.

Output Setting Commands

[SOURce:]CURRENT[:LEVel][:IMMediate][:AMPLitude] {<current>[MIN|MAX]}

This command directly programs the immediate output current level of the output selected with the INST command.

[SOURce:]CURRENT[:LEVel][:IMMediate][:AMPLitude]? [MIN|MAX]

This command checks and returns the immediate current value at the present output terminals of the power supply or the maximum and minimum programmable current levels of the selected output.

For example:

CURR?	Query and return the immediate current value of the output terminals
-------	--

CURR? MAX	Query and return the maximum programmable current level of the output terminals.
-----------	--

CURR? MIN	Query and return the minimum programmable current level of the output terminals
-----------	---

[SOURce:]CURRENT[:LEVel]:LIMit[:AMPLitude] {<current>[MIN|MAX|DEF]}

This command is to set the maximum current limit value of the output selected with INST command.

[SOURce:]CURRENT[:LEVel]:LIMit[:AMPLitude]? [MIN|MAX|DEF]

This query returns the current limit level of the presently selected output or the minimum/ maximum/ default programmable current values of the presently selected output.

[SOURce:]CURRENT[:LEVel]:TRIGgered[:AMPLitude] {<current>[MIN|MAX]}

This command programs the pending triggered current level of the power supply,

which is a stored value and transferred to the output terminals when a trigger occurs. A pending triggered level is not affected by subsequent CURRent commands.

[SOURCE:]CURRent[:LEVel]:TRIGgered[:AMPLitude]? [MIN|MAX]

This query checks and returns the presently programmed triggered current level. If no triggered level is programmed, present CURRent value is returned.

CURRent:TRIGgered? Return the CURRent value or the set triggered current level of the selected output

CURRent:TRIGgered? MAX Return the maximum programmable current value of the selected output

CURRent:TRIGgered? MIN Return the minimum programmable current value of the selected output

VOLTage[:LEVel][:IMMediate][:AMPLitude] {<voltage>|MIN|MAX}

This command directly programs the immediate output voltage level of the output selected with the INST command.

[SOURCE:]VOLTage[:LEVel][:IMMediate][:AMPLitude]? [MIN|MAX]

This command checks and returns the immediate voltage value at the present output terminals of the power supply or the maximum and minimum programmable voltage levels of the selected output. For example:

VOLT? Query and return the immediate voltage value of the output terminals

VOLT? MAX Query and return the maximum programmable voltage levels of the output terminals

VOLT? MIN Query and return the minimum programmable voltage levels of the output terminals

[SOURCE:]VOLTage[:LEVel]:LIMit[:AMPLitude] {<voltage>|MIN|MAX|DEF}

This command is to set the maximum voltage limit value of the presently programmed output selected with INST command.

[SOURCE:]VOLTage[:LEVel]:LIMit[:AMPLitude]? {MIN|MAX|DEF}

This query returns the voltage limit level of the selected output, or the maximum/minimum/default programmable voltage values of the selected output.

[SOURCE:]VOLTage[:LEVel]:TRIGgered[:AMPLitude] {<voltage>|MIN|MAX}

This command programs the pending triggered voltage level of the power supply, which is a stored value and transferred to the output terminals when a trigger occurs. A pending triggered level is not affected by subsequent VOLTage commands.

[SOURCE:]VOLTage[:LEVel]:TRIGgered[:AMPLitude]? [MIN|MAX]

This query checks and returns the presently programmed triggered voltage level. If no triggered level is programmed, the VOLTage value is returned.

VOLTage:TRIGgered? Return the VOLTage value or the set triggered voltage level of the selected output

VOLTage:TRIGgered? MAX Return the maximum programmable voltage values of the selected output

VOLTage:TRIGgered? MIN Return the minimum programmable voltage values of the selected output

Trigger Source Choice

The power supply's system allows a change in the output of the power supply when receiving a trigger. Triggering the power supply includes internal immediate trigger and bus trigger.

Triggering the power supply is a multi-step process:

1. Select an output with the INST:[SELEct] command and then configure the power supply for the triggered output level by using CURRent:TRIGgered and VOLTage:TRIGgered.
2. Specify the source from which the power supply will accept the trigger. The power supply will accept a bus (software) trigger or an immediate trigger.
3. Set the time delay between the detection of the trigger on the specified trigger source and the start of any corresponding output change. Notice that the time delay is valid for only the bus trigger source.
4. Execute an INITiate[:IMMediate] command. If the IMMEDIATE source is selected, the selected output is set to the triggered level immediately. But if the trigger source is the bus, the power supply is set to the triggered level after receiving the Group Execute Trigger (GET) or *TRG command.

Selecting a Trigger Source

You must specify the source from which the power supply will accept a trigger. The trigger is stored in volatile memory; the source is set to bus when the power supply has been off or after a remote interface reset.

Bus (Software) Triggering

1. Select the bus trigger source by sending the following command.
TRIGger:SOURce BUS
2. Trigger the power supply from the remote interface by sending the *TRG command. And the power supply outputs specified triggered output level after the set time delay

if any delay is given.

3. You can also select the trigger source from the USB, RS-232 or GPIB interface. The operation has been introduced before.

Immediate Triggering

1. Select the internal immediate trigger source by sending the following command:

TRIGger:SOURce IMM

2. If the IMMEDIATE source is selected as a trigger source, once the trigger command is executed, the power supply outputs triggered output voltage and current immediately. Any delay is ignored.

Trigger Commands

INITiate[:IMMEDIATE]

This command causes the trigger system to initiate. This command initiates the trigger subsystem when the trigger source is bus and completes one full trigger cycle when the trigger source is the internal immediate.

TRIGger[:SEQuence]:DELay{<second>| MINimum | MAXimum}

This command sets the time delay between the detection of an event on the specified trigger source and the start of any corresponding trigger action on the power supply output. Select from 0 to 3600 seconds. MIN = 0 second. MAX = 3600 seconds. At *RST, this value is set to 0 second.

TRIGger[:SEQuence]:DELay?

This command queries the trigger delay set by bus.

TRIGger[:SEQuence]:SOURce {BUS | IMMEDIATE}

This command selects the source from which the power supply will accept a trigger. The power supply will accept a bus trigger or an internal immediate trigger. At *RST, the bus trigger source is selected.

TRIGger[:SEQuence]:SOURce?

This command queries the present trigger source and returns "BUS" or "IMM".

***TRG**

This command generates a trigger to the trigger subsystem that has selected a bus trigger as its source. The command has the same effect as the Group Execute Trigger (GET) command.

System-Related Commands

DISPlay[:WINDow][:STATE] {OFF | ON}

This command turns the front-panel display on or off. When the display is turned off,

messages are not sent to the display and all annunciators are disabled except the “ERROR” and “Rmt” annunciators.

The display state is automatically turned on when you return to the local mode. After pressing the “Local” key to return to the local state from the remote interface, press any key except for the number keys, knobs, “Resolution”, “Clear”, ”Enter”, and “Track” keys, or “power-on/reset” key to switch to the display status automatically.

DISPlay[:WINDow][:STATe]?

This command queries the front-panel display setting and returns “0” (OFF) or “1” (ON).

DISPlay[:WINDow]:TEXT[:DATA] <quoted string>

This command displays a message on the front panel. The power supply will display up to 12 characters in a message in the form of English letters, Arabic numerals and the blank spaces. Any additional characters are truncated. Each special mark is displayed in the form of the blank space with individual display space. (Except for the single quotes, because which indicate the start and the end of the character string message.) The power supply will not send the output to the display when a message is shown on the front panel.

DISPlay[:WINDow]:TEXT[:DATA]?

This command queries the message sent to the front panel and returns a quoted string.

DISPlay[:WINDow]:TEXT:CLEar

This command clears the message displayed on the front panel, and makes the display exit the character string displaying mode to switch to the immediate mode automatically.

SYSTem:BEEPer[:IMMediate]

This command makes the power supply generates a single beep immediately.

SYSTem:ERRor?

This command queries the power supply’s error queue. When “ERROR” annunciator in the front panel turns on, one or more command syntax or hardware errors have been detected. At present, if this command is sent to the power supply through remote interface, the power supply can return corresponding error messages. Up to 20 errors can be stored in the error queue.

SYSTem:VERSion?

This command queries the power supply to determine the present SCPI version. The returned value is a string in the form YYYY.V where the “YYYY” represent the year of the version, and the “V” represents a version number for that year (for example, 1995.0).

***IDN?**

This query command reads the power supply's identification string. The power supply returns four fields separated by commas. The first field is the manufacturer's name, the second field is the model number, the third field is reserved (always "0"), and the fourth field is a version code which contains three numbers. The first number of the version code is the firmware version number for the main power supply processor; the second is for the input/output processor; and the third is for the front-panel processor. For example:

```
ARRAY,3662A,0,1.3-1.0-1.5
```

***RST**

This command resets the power supply to its power-on state.

Command	State
CURR[:LEV][:IMM]	Output dependent value※
CURR[:LEV]:TRIG	Output dependent value※
DISP[:STAT]	ON
INST[:SEL]	P6V
INST:COUP	NONE
OUTP[:STAT]	OFF
OUTP:TRAC	OFF
TRIG:DEL	0
TRIG:SOUR	BUS
VOLT[:LEV][:IMM]	0
VOLT[:LEV]:TRIG	0

The reset operation sets the output current to the maximum value.

***TST?**

This query performs a complete self-test of the power supply and returns "0" if the self-test passes or "1" if it fails.

***SAV { 0|2 ||9 }**

This command stores the present state of the power supply, which can store 10 sets of operating states from 0 to 9. The state storage features in saving the states or values of INST[:SEL], VOLT[:IMM], CURR[:IMM], OUTP[:STAT], OUTP:TRAC, TRIG:SOUR and TRIG: DEL.

***RCL { 0|2 ||9 }**

This command recalls a previously stored state. To recall a state, you must store it in advance. When recalling a stored state, you must use the same memory location used previously to store the state.



Calibration Commands

CALibration:COUNT?

This command queries the power supply to determine the number of times it has been calibrated.

CALibration:CURRENT[:DATA] <numeric value>

This command can only be used after calibration is unsecured. It enters a current value of a selected output that you obtained by reading an external meter. You must first select a calibration level (CAL:CURR:LEV) for the value being entered. Two successive values (one for each end of the calibration range) must be selected and entered. The power supply then computes new calibration constants, which are then stored in internal memory.

CALibration:CURRENT:LEVEL {MINimum | MAXimum}

Before using this command, you must select the output which is to be calibrated by INSTRUMENT command. This command can only be used after calibration is unsecured. It sets the power supply to a calibration point that is entered with CALibration:CURRENT[:DATA] command. During calibration, two calibration points must be entered and the low-end point (MIN) must be selected and entered first.

CALibration:SECure:CODE <new code>

This command enters a new security code. To change the security code, first unsecure the power supply with the old security code. Then, enter the new one.

CALibration:SECure:STATE {OFF | ON>}, <code>

This command secures or unsecures the power supply for calibration.

CALibration:SECure:STATE?

This command queries and returns the current secured state for calibration of the power supply. The returned parameter is “0” (unsecured) or “1” (secured).

CALibration:STRing <quoted string>

This command records calibration information about your power supply.

For example, you can store such information as the calibrator and the calibration date.

CALibration:STRing?

This command queries the calibration message and returns a quoted string.

CALibration:VOLTage[:DATA] <numeric value>

This command can only be used after calibration is unsecured. It enters a voltage value of a selected output that you obtained by reading an external meter. You must first select a calibration level (CAL:VOLT:LEV) for the value being entered. Two successive values (one for each end of the calibration range) must be selected and entered. The power supply then computes new voltage calibration constants, which

are then stored in internal memory.

CALibration:VOLTage:LEVel {MINimum | MAXimum}

Before using this command, you must select the output which is to be calibrated by INSTRUMENT command. This command can only be used after calibration is unsecured. It sets the power supply to a calibration point that is entered with CALibration:VOLTage[:DATA] command. During calibration, two calibration points must be entered and the low-end point (MIN) must be selected first.

RS-232 Interface Commands

SYSTem:LOCal

This command makes the power supply switch to local mode from remote mode. All keys on the front panel are fully functional. The “Rmt” annunciator on the display is off.

SYSTem:REMOte

This command places the power supply in the remote mode. All keys on the front panel, except the “Local” key, are disabled. The “Rmt” annunciator on the display is on.

SYSTem:RWLock

This command places the power supply in the remote mode. All keys on the front panel, including the “Local” key, are disabled. The “Rmt” annunciator on the display is on.

Ctrl-C

This command clears the operation in progress over remote interface and discards any pending output data.

The SCPI Status Registers

All SCPI instruments implement status registers in the same way. The status system records various instrument conditions in three register groups: the Status Byte register, the Standard Event register, and the Questionable Status register group. The Status Byte register records high-level summary information reported in the other register groups. Chapter Five will illustrate how to use SCPI status registers.

What is an Event Register?

An event register is a read-only register that reports defined conditions within the power supply. Bits in an event register are latched. Once an event bit is set, subsequent state changes are ignored. Bits in an event register are automatically cleared by a query command of that register (such as *ESR? Or STAT:QUES:EVEN?) or by sending the *CLS command. A reset (*RST) or device clearance command will

not clear bits in event registers. Querying an event register returns a decimal value which corresponds to the binary-weighted sum of all bits set in the register.

What is an Enable Register?

An enable register defines which bits in the corresponding event register are logically ORed together to form a single summary bit. Enable registers are both readable and writable. Querying an enable register will not clear it. The *CLS (clear status) command does not clear enable registers but it does clear the bits in the event registers. To enable bits in an enable register, you must write a decimal value which corresponds to the binary-weighted sum of the bits you wish to enable in the register.

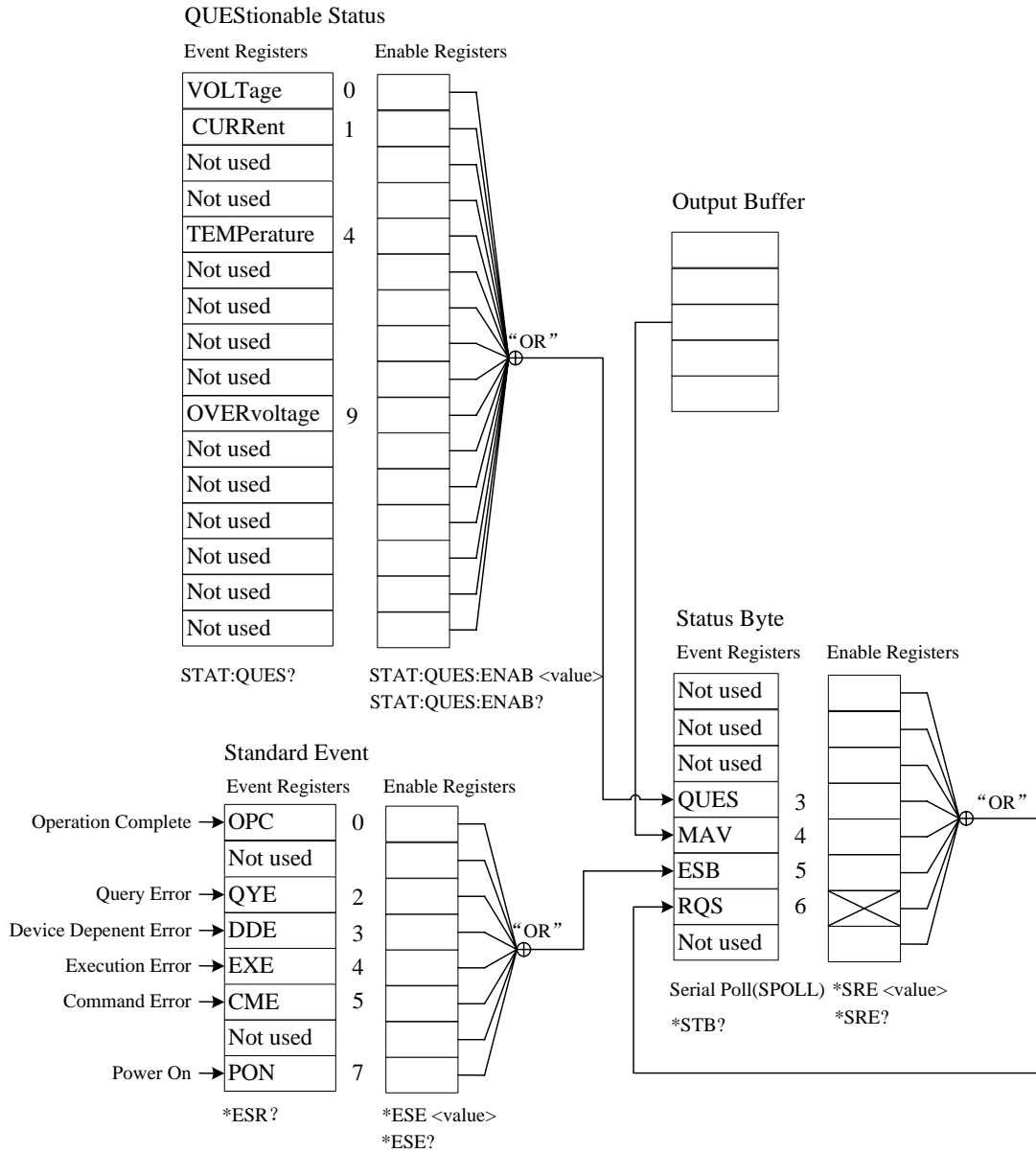

The Questionable Status Register

The questionable status register provides information relate to the abnormal operation of the power supply. When Bit 0 is 1. the power supply is in constant voltage mode and when Bit 1 is 1, the power supply is in constant current mode. Bit 4 reflects power supply’s operating temperature. When bit 9 is 1, it indicates that the power supply is in over-voltage state and its over-voltage circuit begins to work. Query the value of this register with STATus:QUEStionable? Command.

Bit Definitions - Questionable Status Register

Bit	Decimal Value	Definition
0(Voltage)	1	The power supply is in constant voltage mode.
1(Current)	2	The power supply is in constant voltage mode.
2-3(Not used)	0	Always set to 0.
4(Over-temperature)	16	The fan has a fault condition.
5-8(Not used)	0	Always set to 0.
9(Over Voltage)	512	The power supply is in over-voltage state.
10-15(Not used)	0	Always set to 0.

The questionable status event register is cleared when:

1. You execute the *CLS (clear status) command.
2. You query the event register with STATus:QUEStionable [:EVENT]? (Status Questionable Event register) command

The questionable status enable register is cleared when you execute STATus:QUEStionable:ENABle 0 command.

The Standard Event Register

The standard event register reports the following instrument events: power-on detected errors, command syntax errors, command execution errors, self-test or calibration errors, query errors, or an *OPC command. Any or all of these conditions can be reported in the standard event summary bit of status byte register through the enable register. To set the enable register mask, you write a decimal value to the register using the *ESE (Event Status Enable) command.

Bit Definitions - Standard Event Register

Bit	Decimal Value	Definition
0 OPC	1	Operation Complete. All commands prior to and including an *OPC command have been executed.
1 not used	0	Always set to 0.
2 QYE	4	Query Error. The power supply tried to read the output buffer but it was empty. Or, new command line was received before a previous query had been read. Or, both the input and output buffers are full.
3 DDE	8	Device Error. A self-test or calibration error occurred.
4 EXE	16	Execution Error. An execution error occurred.
5 CME	32	Command Error. A command syntax error occurred.
6 not used	0	Always set to 0.
7 PON	128	Power On. Power has been turned off and on since the last time the event register was read or cleared

The standard event register is cleared when:

1. You execute the *CLS (clear status) command.
2. You query the event register using the *ESR? (Event Status register) command.

For example, if 28 (4 + 8 + 16) is returned when you query the status of the standard event register, it is convinced that QYE, DDE, and EXE conditions have occurred.

The standard event enable register is cleared when:

1. You execute the *ESE 0 command.
2. You turn on the power and have configured the power supply using the *PSC 1 command.
3. The enable register will not be cleared at power-on if you have configured the power supply with the *PSC 0 command.

For example, you must send *ESE 24 (8 + 16) to enable DDE and EXE bits.

The Status Byte Register

The status byte summary register reports conditions from the other status registers. Query data that is waiting in the power supply's output buffer is immediately reported through the "Message Available" bit (bit 4) of status byte register. Bits in the summary register are not latched. Clearing an event register will clear the corresponding bits in the status byte summary register. Reading all messages in the output buffer, including any pending queries, will clear the message available bit.

Bit Definitions - Status Byte Summary Register

Bit	Decimal Value	Definition
0-2 not used	0	Always set to 0
3 QUES	8	One or more bits are set in the status register.
4 MAV	16	Data is available in the power supply's output buffer.
5 ESB	32	One or more bits are stored in the standard event register.
6 RQS	64	The power supply is requesting service (serial poll).
7 not used	0	Always set to 0

The status byte summary register is cleared when:

1. You execute the *CLS (clear status) command.
2. Querying the standard event register (*ESR? command) will clear only bit 5 in the status byte summary register.

For example, if 24 (8 + 16) is returned when you query the status of the Status Byte register, it is convinced that QUES and MAV conditions have occurred.

The status byte enable register (Request Service) is cleared when:

1. You execute the *SRE 0 command.
2. You turn on the power and have configured the power supply using the *PSC 1 command.
3. The enable register will not be cleared at power-on if you have configured the power supply using *PSC 0.

For example, you must send *SRE 96 (32 + 64) to enable ESB and RQS bits.

Status Reporting Commands

SYSTEM:ERRor?

This query command reads one error from the error queue. When the front-panel ERROR annunciator turns on, one or more command syntax or hardware errors have been detected. A record of up to 20 errors can be stored in the power supply's error

queue. The additional errors will not be stored.

1. Errors are stored and retrieved in first-in-first-out (FIFO) order. The first error returned is the first error that was stored. When you have read all errors from the queue, the “ERROR” annunciator turns off.
2. If more than 20 errors have occurred, the last error stored in the queue (the most recent error) is replaced with -350, “Too many errors”. No additional errors are stored until you read or remove errors from the queue. If no errors have occurred when you execute this command, the power supply responds with “+0”, “No error”.
3. The error queue is cleared when the power has been off or a *CLS (clear status) command has been executed. The *RST (reset) command does not clear the error queue.

STATUS:QUESTIONABLE[:EVENT]?

This command queries the questionable status event register. The power supply returns a decimal value which corresponds to the binary-weighted sum of all bits in the register.

STATUS:QUESTIONABLE:ENABLE <enable value>

This command enables or disables bits in the questionable status event register. The selected bits are then reported to the status byte.

STATUS:QUESTIONABLE:ENABLE?

This command queries the questionable status enable register. The power supply returns a decimal value representing the bits set in the enable register and corresponding to the binary-weighted sum of all bits in the register.

***CLS**

This command clears all event registers and status byte register.

***ESE <enable value>**

This command enables bits in the standard event enable register. The selected bits are then reported to the status byte.

***ESE?**

This command queries the standard event enable register. The power supply returns a decimal value which corresponds to the binary-weighted sum of all bits in the register.

***ESR?**

This command queries the standard event register. The power supply returns a decimal value which corresponds to the binary-weighted sum of all bits in the register.

***OPC**

This command sets the “Operation Complete” bit (bit 0) of the standard event register after the command is executed.

***PSC { 0 | 1 }**

(Power-on status clear.) This command clears the status byte and the standard event register enable masks when power is turned on (*PSC 1). When *PSC 0 is in effect, the status byte and standard event register enable masks are not cleared when power is turned on.

***PSC?**

This command queries the power-on status clear setting. The returned parameter is “0” (*PSC 0) or “1” (*PSC 1).

***SRE <enable value>**

This command enables bits in the status byte enable register.

***SRE?**

This command queries the status byte enable register. The power supply returns a decimal value which corresponds to the binary-weighted sum of all bits set in the register.

***STB?**

This command queries the status byte summary register. The *STB? command is similar to a serial poll but it is processed like any other instrument command. The *STB? command returns the same result as a serial poll but the “Request Service” bit (bit 6) is not cleared if a serial poll has occurred.

***WAI**

This command instructs the power supply to wait for all pending operations to complete before executing any additional commands over the interface. Used only in the triggered mode.

SCPI Conformance Information

The SCPI commands relevant to the power supply operation are introduced in detail in this manual, and most of their usage and formats are in accordance with the standard SCPI Commands. There are still some commands required by the standard SCPI commands not being introduced but it is not necessary for the users to know them.

SCPI Confirmed Commands

The following commands are introduced in this manual:

DISPlay

[[:WINDow]::STATe] {OFF|ON}
[:WINDow]::STATe]?
[:WINDow]:TEXT[:DATA] <quoted string >
[:WINDow]:TEXT[:DATA]?
[:WINDow]:TEXT:CLEar

MEASure

[[:SCALar]::CURRent[:DC]?
[:SCALar] :VOLTage[:DC]?

OUTPUT

[[:STATe] {OFF|ON}
[:STATE]?

[SOURce:]

CURRent[:LEVel]::IMMediate[::AMPLitude] {<current>|MIN|MAX}
CURRent[:LEVel]::IMMediate[::AMPLitude]? [MIN|MAX]
CURRent[:LEVel]:TRIGgered[::AMPLitude] {<current>|MIN|MAX}
CURRent[:LEVel]:TRIGgered[::AMPLitude]?[MIN|MAX]
VOLTage[:LEVel]::IMMediate[::AMPLitude] {<voltage>|MIN|MAX}
VOLTage[:LEVel]::IMMediate[::AMPLitude]?[MIN:MAX]
VOLTage[:LEVel]:TRIGgered[::AMPLitude] {<voltage>|MIN|MAX}
VOLTage[:LEVel]:TRIGgered[::AMPLitude]?[MIN|MAX]

STATus

:QUESTionable[:EVENT]?
:QUESTionable:ENABle <enable value>
:QUESTionable:ENABle?
:QUESTionable:ENABle <enable value>

SYSTem

:BEEPer[:IMMediate]
:ERRor?
:VERSion

TRIGger

[[:SEQuence]::DELay {<second>|MIN|MAX}
[:SEQuence]::DELay?
[:SEQuence]::SOURce{BUS|IMM}
[:SEQuence]::SOURce?

INITiate[:IMMediate]

Device-Specific Commands

The following commands are specific to the ARRAY 366XA power supply. However, these commands are designed with the SCPI Command in mind and they follow all of the syntax rules defined by the standard command.

List as follow:

APPLy

[{<voltage>|DEF|MIN|MAX>}[, {<current>|DEF|MIN|MAX}]]

APPLy?

CALibration

:COUNT?

:CURRENT[:DATA] <numeric value>

:CURRENT:LEVEL {MIN|MAX}

:SECure:CODE <new code>

:SECure:STATE {OFF|ON}, <voltage>

:SECure:STATE?

:STRING <quoted string >

:STRING?

:VOLTage[:DATA] <numeric value>

:VOLTage:LEVEL {MIN|MAX}

MEASure

[:SCALAR]:CURRENT [:DC]?

[:SCALAR]:VOLTage[:DC]?

[:SCALAR]:TEMPerature?

[SOURce:]

CURRENT[:LEVEL]:LIMIT[:AMPLitude] { <current>|MIN|MAX|DEF }

CURRENT[:LEVEL]:LIMIT[:AMPLitude]? {MIN|MAX|DEF}

VOLTage[:LEVEL]:LIMIT[:AMPLitude] { <voltage>|MIN|MAX|DEF }

VOLTage[:LEVEL]:LIMIT[:AMPLitude]? {MIN|MAX|DEF}

SYSTem

:LOCAL

:REMOTE

:RWLOCK

Chapter 5 Application Programs

Application Programs

RS-232 Operation Using QuickBASIC

The following example shows how to send command instruction and receive command responses over the RS-232 interface using QuickBASIC. This program has been tested and can be used directly.

RS-232 operation using QuickBASIC

```
CLS      ' clear the display
LOCATE 1, 1
          ' Set the cursor at the first line of the first row
DIM Recv$(100)
          ' Restore and receive the data array
OPEN "COM1:9600, N, 8, 2, RS, LF, PE" FOR RANDOM AS #1 LEN = 1000
' Baud Rate: 9600
' Parity Check: None
' Data Bit: 8
' Stop Bit: 2
' RS: sending RTS signal is forbidden
' LF: a <carriage return> followed by a <new line> automatically
' Visit: Random
' File number: 1
' #1 Length: 1000
PRINT #1, "SYST:REM"
' Put the power supply into the remote operation mode
PRINT #1, "OUTP ON"
' Enable the outputs
PRINT #1, "SYST:ERR?"
' Error message
LINE INPUT #1, Recv$
' Receive the data from the power supply
PRINT "SYST:ERR? : ", Recv$
' Output the received data on the display
```

Chapter 6 Tutorial Tutorial

The ARRAY 366XA is a high performance instrument capable of delivering clean dc power. But to take full advantage of the performance characteristics designed into the power supply, certain basic precautions must be observed when it is connected for use on the lab bench or as a controlled power supply. This chapter gives specific details on the operation of the ARRAY 366XA power supply.

An Overview of ARRAY 366XA Operation

The ARRAY 366XA has a very precise regulating properties and respond quickly to variations of the line and load. These supplies also exhibit low ripple and noise, the tolerance of ambient temperature changes, circuit simplicity, and a high reliability.

The ARRAY 366XA is controlled by a control circuit that provides voltages to program the outputs. The power supply sends the output voltages back to the control circuit. The control circuits receive information from the front panel and send instant information to the display. At the same time, the control circuit also receives and returns the corresponding values over the remote interface.

The remote interface is isolated from the control circuit and the power supply.

Output Characteristics

An ideal constant-voltage power supply would have a zero output impedance at all frequencies. Thus, the voltage would remain perfectly constant in spite of any changes in output current demanded by the load. The ideal constant-current power supply exhibits infinite output impedance at all frequencies. Thus the output voltage of the ideal constant-current power supply would change correspondingly when a load change occurred in order to maintain its output current at a constant value.

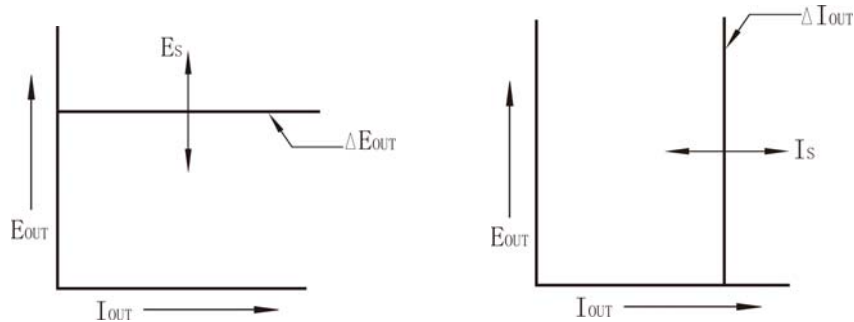

Ideal Constant Voltage Mode

Ideal Constant Current Mode

The ARRAY 366XA power supply outputs can operate in either constant-voltage (CV) mode or constant-current (CC) mode. Under certain fault conditions, the power supply can not operate in either CV or CC mode and becomes unregulated.

Figure below shows the operating modes of the three outputs of the power supply. The operating point of one supply will be either above or below the line $R_L = R_C$. This line represents a load where the output voltage and the output current are equal to the voltage and current setting. When the load R_L is greater than R_C , the output voltage will dominate since the current will be less than the current setting. The power supply is said to be in constant-voltage mode. The load at point A has a relatively high resistance value (compared to R_C), the output voltage is at the voltage setting, and the output current is less than the current setting. In this case the power supply is in the constant-voltage (CV) mode and the current setting acts as a current limit.

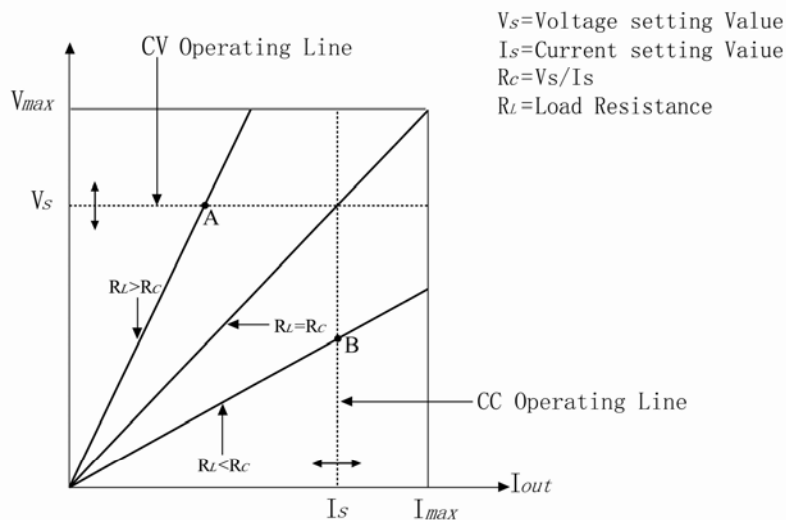

When the load R_L is less than R_C , the output current will dominate since the voltage will be less than the set voltage. The power supply is said to be in constant-current mode. The load at point B has a relatively low resistance, the output voltage is less than the voltage setting, and the output current is at the current setting. The supply is in constant-current (CC) mode and the voltage setting acts as a voltage limit.

Unregulated State

If the power supply goes into a operation mode that is neither CV nor CC, the power supply is in unregulated mode, which may occur momentarily. In this mode the output voltage and current are not predictable. The unregulated condition may be the result of the input AC voltage below the specifications or caused by non-resistive load. For example, when the output is programmed for a large voltage step, the output capacitor or a large capacitive load will charge up at the current limit setting. During the ramp up of the output voltage the power supply will be in the unregulated mode. During the transition from CV to CC as the output is shorted, the unregulated state may occur briefly during the transition.

Unwanted Signals

An ideal power supply has a perfect current or voltage output with no signals across the terminals or from the terminals to earth ground. The actual power supply has finite noise across the output terminals and finite noise from either terminal to earth ground.

And the noise across the output terminals is of very low value in the ARRAY 366XA.

The noise from the terminals to earth ground can be a problem for very sensitive circuitry that is referenced to earth ground. When a circuit is referenced to earth ground, a low level line-related AC current will flow from the output terminals to earth ground. Any impedance to earth ground will create a voltage drop equal to the current flow multiplied by the impedance. To minimize this effect, the output terminal can be grounded at the output terminal. Alternately, any impedance to earth ground should have a complementary impedance to earth ground to cancel generated voltages.

Connecting the Load

Output Isolation

The output of the power supply is isolated from earth ground and the power supply can be connected to the ground with the earth ground terminal when needed. Any output terminal can be grounded, and an external voltage source may be connected between any terminal output and ground. However, output terminals must be kept within ± 240 Vdc of ground. An earth ground terminal is provided on the front panel for convenience.

Multiple Loads

When connecting multiple loads to the power supply, each load should be connected to the output terminals with separate connecting wires. This minimizes mutual coupling effects between loads and takes full advantage of the low output impedance of the power supply. Each pair of wires should be as short as possible and twisted or shielded to reduce lead inductance and noise pick-up. And for safety consideration, connecting lead with a large diameter is preferred to avoid overheat in heavy current condition. If a shield is used, connect one end to the power supply ground terminal and leave the other end disconnected.

If cabling considerations require the use of distribution terminals that are located remotely from the power supply, connect output terminals to the distribution terminals by a pair of twisted or shielded wires. Connect each load to the binding terminals separately.



To satisfy safety requirements, load wires must be heavy enough to avoid overheat while carrying the high output current of the power supply.

Considerations

During the operation of the power supply, various problems may occur because of the difference in connected loads, which will be introduced as follow respectively.

Capacitive Load

In most cases, the power supply will be stable for capacitive load of any size. Load with large capacitor may cause ringing in the power supply's transient response. It is possible that certain combinations of load will result in output instability. And the problem may be solved by properly decreasing the total load capacitance.

A large capacitor at the output terminals may cause the power supply to cross into CC or unregulated mode momentarily when the output is enabled. The slew rate of the output voltage will be limited to the current setting divided by the total load capacitance (internal and external).

Signal	Internal Capacitance	Internal Load Current	Slew Rate at No Load and Full Scale Current Setting
3662A	3000uF	0.65A	2V/msec
3663A	1440uF	0.3A	4V/msec
3664A	660uF	0.15A	6V/msec

Inductive Load

Inductive loads present no loop instability in constant voltage mode. In constant current mode, inductive loads form a parallel resonance with the power supply's output capacitor. Generally this will not affect the stability of the power supply, but it may cause ringing instantaneously when the power supply responds to the output..

Pulse Load

In some applications the load current varies within a large range. The constant current circuit limits the output current. Some peak loading exceeding the current limit can be obtained from the output capacitor. To stay within the specifications for the output, the current limit should be set greater than the peak current expected or the supply may go into CC mode or unregulated mode.

Reverse Current Load

An external source is not allowed to pump current into the supply. A reverse current loading may risk the loss of regulation and the damage of the power supply.

Extending the output

The ARRAY 366XA provides corresponding outputs, and enables the power supply to provide voltages or currents greater than its rated maximum outputs with different connecting measures when needed.

Series operation of two or more power supplies can obtain a higher voltage output than that is available from a single supply. Series connected power supplies can be operated with one load across power supplies. The power supply has a related internal protection function so that if operated in series with other power supplies, damage will not occur when the load is short-circuited or the series-wound power supply are not turned on simultaneously.

Reliability

Reliability of the power supply depends heavily on the ambient condition, in which the humidity and temperature will affect the reliability. The lower the temperature of the components, the better the reliability. When the power supply is in operation, an internal fan installed in the rear of power supply can keep the temperature of components low. To assist in cooling, please leave some room at the sides and rear of the power supply.

Chapter 7 Specifications

Specifications

The performance specifications of ARRAY 366XA are listed in this chapter in details (Specifications are warranted in the temperature range of $25\pm 2^{\circ}\text{C}$ with a resistive load.). Please consult the relevant data in actual use.

Performance Specifications

	3662A	3663A	3664A
Output Ratings			
Voltage	0~35V	0~80V	0~120V
Current	0~14.5A	0~6.5A	0~4.2A
Ripple and Noise (20 Hz to 20 MHz)			
Voltage (root mean square value)	<5mVrms	<8mVrms	<8mVrms
Voltage (peak-to-peak value)	<10mVp-p	<14mVp-p	<18mVp-p
Current	<2mArms	500uArms	500uArms
Common Mode Current	1.5mArms	1.5mArms	1.5mArms
Load Regulation			
Voltage	1mV	1mV	2mV
Current	1mA	0.5mA	0.3mA
Line Regulation			
Voltage	1mV	1mV	2mV
Current	1mA	0.5mA	0.3mA
Programming Accuracy			
Voltage	0.03%+5mV	0.03%+10mV	0.03%+15mV
Current	0.03%+6mA	0.03%+3mA	0.03%+2mA
Readback Accuracy			
Voltage	0.02%+2mV	0.02%+5mV	0.02%+8mV
Current	0.02%+5mA	0.02%+2.5mA	0.02%+1.5mA
Programming Resolution			
Voltage	1mV	2mV	4mV

Current	1mA	1mA	1mA
Readback Resolution			
Voltage	1mV	2mV	4mV
Current	1mA	1mA	1mA
Meter Resolution			
Voltage	1mV	2mV	4mV
Current	1mA	1mA	1mA

Transient Response Time

Less than 1ms for output to recover to within 100 mV following a change in output current from full load to half load or vice versa

Command Processing Time

Programming Commands: Maximum time for output to change after receiving APPLy and SOURce commands: <50msec

Readback Command: Maximum time to readback output MEASure? command: <100msec

The Other Commands: < 50msec

Supplemental Characteristics

Output Programming Range (maximum programmable values)

	3662A	3663A	3664A
Voltage	0~35.2V	0~80.2V	0~120.2V
Current	0~14.5A	0~6.5A	0~4.2A

Temperature Coefficient, \pm (% of output + offset)

Maximum change in output/readback per °C after a 30-minute warm-up.

	3662A	3663A	3664A
Voltage	30ppm + 0.5mV	30ppm+ 0.8mV	30ppm+ 1mV
Current	30ppm + 0.2mA	30ppm+ 0.1mA	30ppm + 0.1mA

Stability, \pm (% of output + offset)

Following a 30-minute warm-up, the change occurs in output within 8 hours under constant load, line, and ambient temperature.

	3662A	3663A	3664A
Voltage	0.02% + 2mV	0.02% +3mV	0.02% + 4mV
Current	0.02% + 6mA	0.02% + 3mA	0.02% +2mA

Voltage Programming Speed

Maximum time required for output voltage to settle within 1% of its total excursion (for resistive load). Command processing time is excluded.

	3662A	3663A	3664A
Full load Up	20msec	22msec	22msec
Full load Down	22msec	22msec	22msec
No load Up	20msec	20msec	22msec
No load Down	22msec	22msec	22msec

AC Input Ratings

AC100V-240V	47Hz~63Hz	750VA Max
-------------	-----------	-----------

Operating Temperature

0~40°C	0~80%RH
--------	---------

Cooling

Fan Cooling

Programming Language

SCPI (Standard Commands for Programmable Instruments)

Recommended Calibration Interval

1 year

Net Weight

5.5 kg

Dimensions

212.6mm(W)×132.6mm(H)×360mm(D) (8.4×5.2×14.2 in)
--

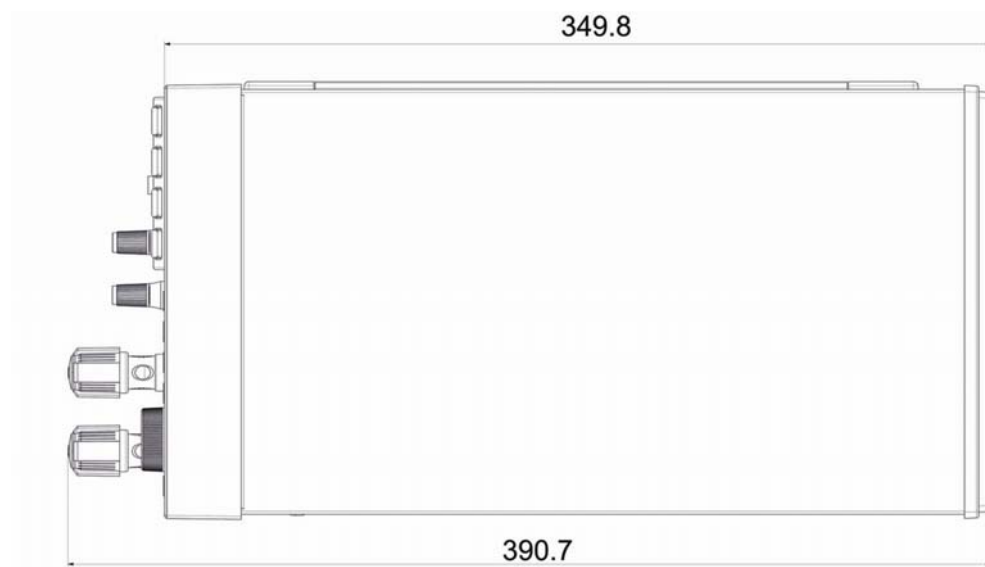
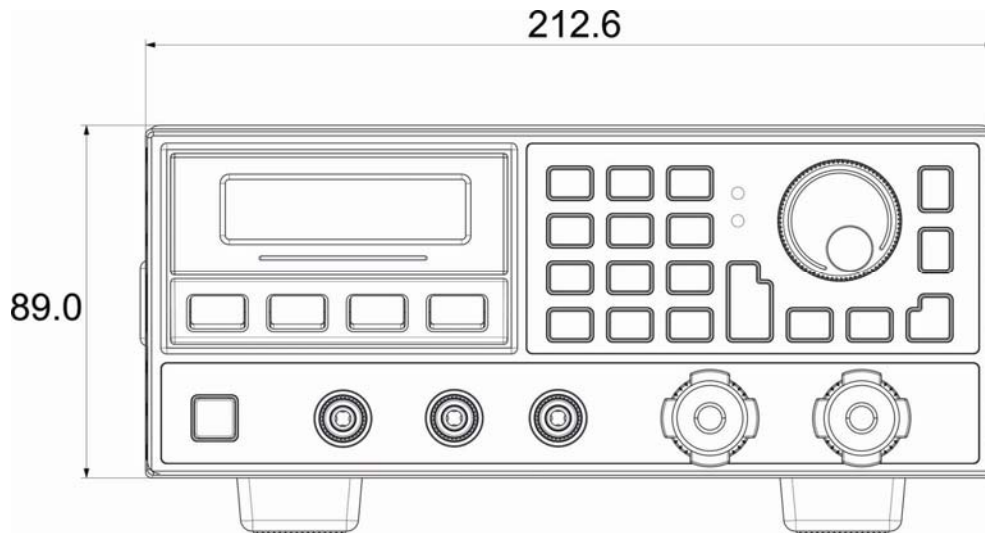

APPENDIX Error Messages

Error Messages

When the front-panel ERROR annunciator turns on, and the power supply generates a short beep, one or more command syntax or hardware errors have been detected. A record of up to 20 errors is stored in the power supply's memory.

Errors are stored and retrieved in first-in-first-out (FIFO) order. The first error returned is the first error that was stored. When you have read or cleared all errors from the queue, the ERROR annunciator turns off automatically.

If more than 20 errors have occurred, the last error stored in the queue (the most recent error) is replaced with -350, "Too many errors". No additional errors are stored until you read or remove errors from the queue. If no errors have occurred when you read the error queue, the supply responds with + 0, "No error".

The error queue is cleared after a *CLS (clear status) command has been executed. The *RST (reset) command does not clear the error queue. All error records will be lost when the power is turned off.

Front-Panel operation:

If the ERROR annunciator is on, press the "Error" key repeatedly to read the errors stored in the queue in sequence. The error queue is cleared when you read all errors and then the "ERROR" annunciator turns off.

Remote interface operation:

SYSTEM:ERROR? Read one error from the error queue

Execution Errors

Code	Explanation
------	-------------

-101	Invalid character
------	--------------------------

An invalid character was found in the command string. You may have inserted a character such as #, \$, or % in the command keyword or within a parameter.

Example: OUP:TRAC #ON

-102	Syntax error
------	---------------------

Invalid syntax was found in the command string. You may have inserted a blank space before or after a colon in the command header, or before a comma.

Example: VOLT:LEV ,1

-103	Invalid separator
------	--------------------------

An invalid separator was found in the command string. You may have replaced a

colon, semicolon, or blank space with a comma or you may have replaced a comma with a blank space.

Example: TRIG:SOUR,BUS or APPL P6V 1.0 1.0

-104 Data type error

The wrong parameter type was found in the command string. You may have specified a number where a string was expected, or vice versa.

-108 Parameter not allowed

More parameters were received than expected for the command. You may have entered an extra parameter, or you added a parameter to a command that does not accept a parameter.

Example: APPL? 10

-109 Missing parameter

Fewer parameters were received than expected for the command. You omitted one or more parameters that are required for this command.

Example: APPL

-112 Program mnemonic too long

A command header was received which contained more than the maximum 12 characters allowed.

-113 Undefined header

A command was received that is not valid for this power supply. You may have misspelled the command or it may not be a valid command. If you are using the short form of the command, remember that it may contain up to four letters.

Example: TRIGG:DEL 3

-123 Numeric overflow

A numeric parameter was found whose exponent was larger than 32,000.

-124 Too many digits

A numeric parameter was found whose mantissa contained more than 255 digits, excluding leading zeros.

-131 Invalid suffix

A suffix was incorrectly specified for a numeric parameter. You may have misspelled the suffix.

Example: TRIG:DEL 0.5 SECS

-134 Suffix too long

A suffix for a numeric parameter contained too many characters.

- 138 **Suffix not allowed**
A suffix was received following a numeric parameter which does not accept a suffix.
Example: STAT:QUES:ENAB 18 SEC (SEC is not a valid suffix).
- 144 **Character data too long**
The character data element contained too many characters.
- 151 **Invalid string data**
An invalid character string was received. Check if you have enclosed the character string in single or double quotes.
Example: DISP:TEXT 'ON
- 211 **Trigger ignored**
A Group Execute Trigger (GET) or *TRG was received but the trigger was ignored. Make sure that the trigger source is selected to the bus and the trigger subsystem should be initiated by INIT[:IMM] command.
- 213 **Init ignored**
A Group of INIT[:IMM] was received when the bus line is selected as the trigger source. Make sure that the trigger source is selected to the bus and the trigger subsystem is initiated by INIT[:IMM] command, then triggered by *TRG.
- 222 **Data out of range**
A numeric parameter value exceeds the valid range for the command.
Example: TRIG:DEL -3
- 223 **Too much data**
A character string was received but could not be executed because the string length was more than 40 characters. This error can be generated by the CALibration:STRing command.
- 224 **Illegal parameter value**
A discrete parameter was received which was not a valid choice for the command. You may have used an invalid parameter choice.
Example: DISP:STAT ABC (ABC is not a valid choice).
- 350 **Too many errors**
The error queue is full because more than 20 errors have occurred. No additional errors are stored until you remove errors from the queue. The error queue is cleared when power has been off, or after a *CLS (clear status) command has been executed.
- 410 **Query INTERRUPTED**
A command was received which sends data to the output buffer, but the output buffer contained data from a previous command (the previous data is not overwritten). The

output buffer is cleared when power has been off, or after a *RST (reset) command has been executed.

-420 Query UNTERMINATED

The power supply was addressed to talk (i.e., to send data over the interface) but a command has not been received which sends data to the output buffer. For example, you may have executed an APPLy command (which does not generate data) and then attempted an ENTER statement to read data from the remote interface.

-430 Query DEADLOCKED

A command was received which generates too much data to fit in the output buffer and the input buffer is also full. Command execution continues but all data is lost.

501 Isolator UART framing error

502 Isolator UART overrun error

511 RS-232 framing error

512 RS-232 overrun error

513 RS-232 parity error

521 Input buffer overflow

522 Output buffer overflow

Self-Test Errors

Code	Explanation
601	Front panel does not respond
603	System ADC test failed
607	Rundown too noisy
630	Fan test failed
631	System DAC test failed
632	Hardware test failed
633	Temperature Sensor disconnect

Calibration Errors

Code	Explanation
-------------	--------------------

702	Cal secured
------------	--------------------

The calibration is secured.

703	Invalid secure code
------------	----------------------------

An invalid calibration security code was received when attempting to unsecure or secure the power supply. You must use the same security code to unsecure the power supply as what was used to secure it, and vice versa. The security code may contain up to 12 alphanumeric characters.

704	Secure code too long
------------	-----------------------------

A security code was received which contained more than 12 characters.

740	Cal checksum failed, secure state
------------	--

741	Cal checksum failed, string data
------------	---

745	Cal checksum failed, DAC cal constants
------------	---

746	Cal checksum failed, readback cal constants
------------	--

747	Cal checksum failed, GPIB address
------------	--

748	Cal checksum failed, internal data
------------	---

750	Cal checksum failed, store/recall data in location 0
------------	---

751	Cal checksum failed, store/recall data in location 1
------------	---

752	Cal checksum failed, store/recall data in location 2
------------	---

753	Cal checksum failed, store/recall data in location 3
------------	---

754	Cal checksum failed, store/recall data in location 4
------------	---

755	Cal checksum failed, store/recall data in location 5
------------	---

756	Cal checksum failed, store/recall data in location 6
------------	---

757	Cal checksum failed, store/recall data in location 7
------------	---

758 **Cal checksum failed, store/recall data in location 8**

759 **Cal checksum failed, store/recall data in location 9**