

CSI Station 1A / 2A

Soldering Station Instruction Manual

Thank you for purchasing our *CSI station 1A / 2A*
temperature controlled soldering station.
Please read the manual before using the unit.
Keep manual in accessible place for future reference.

Table of Contents

Package Content.....	3
Specifications	3
Safety Precautions	4
Assembly Instructions	4
Operating Instructions	5
Tip Care and Maintenance	6
Calibrating the iron temperature	6
Disassembling Hand piece	7
Replacing Heating element	8
Troubleshooting connections	8
Replacing Cord	9
Replacing Fuse	10
Basic Troubleshooting Guide	10

CSI Station 1A / 2A

Soldering Station Instruction Manual

Thank you for purchasing our CSI station
temperature controlled soldering station.
Please read the manual before using the
Keep manual in accessible place for future reference.

Table of Contents

Assembly Instructions	1
Operating Instructions	2
Tip Care and Maintenance	3
Calibrating the Station	4
Heat-sensiting Hand piece	5
Repacking Heating Element	6
Repacking Temperature	7
Replacing Cord	8
Replacing Fuse	9
How to troubleshoot	10

PACKAGE CONTENT

Please check if the listed parts below are included in the package:

- Main Station 1 unit
- Soldering Iron 1 pc.
- Soldering Iron Stand 1 pc.
- Instruction Manual 1 pc.
- Power Cord 1 pc.

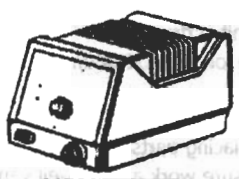

Main Station



Soldering Iron



Power cord



Soldering Iron stand

SPECIFICATION

Power Consumption	40W
Output Voltage	24V
Temperature Range	200—480 °C/392—896°F
Dimension	110(w)×93(l)×168(h) mm
Power Consumption	24V—60W
Tip to Ground Resistance	Less than 2 Ohm
Heating Element	Ceramic Heating Element
Weight	100 grams

Specification might change without prior notice.

CARE and SAFETY PRECAUTIONS

CAUTION: Misuse may cause injury and physical damage. For your own safety, be sure to comply with the following precaution.

- Temperature may reach a high of 480°C when turned on.
 - Do not use near flammable gases, paper and other materials.
 - Do not touch heated parts, can cause severe burns.
 - Do not touch metallic parts near the Tip.
- Handle with Care
 - Never drop or sharply jolt the unit.
 - Contains delicate parts that may break if unit is dropped.
- Disconnect plug when not to be used for a long period of time.
 - Turn off power during breaks.
- Use only genuine replacement parts.
 - Turn-off power and let unit cool before replacing parts.
- Soldering process produces smoke, make sure work area is well ventilated.
- Do not modify unit
- Never touch the element or tip of the soldering iron. They are very hot (about 400°C) and will give you a nasty burn.
- Always return the soldering iron to its stand when not in use.

ASSEMBLY INSTRUCTIONS

SOLDERING IRON HOLDER

1. Install solder wire to the solder iron holder. (Fig. 1)
2. Dampen the cleaning sponge with water, squeeze it dry and place it in its base. (Fig. 2)

Note: Failure to dampen sponge might damage the soldering tip.

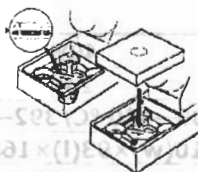

Fig. 2

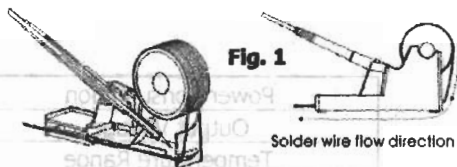

Fig. 1

Solder wire flow direction

SOLDERING IRON

1. Attach the soldering iron to the receptacle connector at the bottom right area of the main unit.
2. Place soldering iron to the soldering iron stand as shown in Fig. 1
3. Plug the power cord into a receptacle with ground.

Note: Failure to dampen sponge might damage the soldering tip.

OPERATING INSTRUCTIONS

1. Follow procedures shown in the "Assembly Instructions".
2. Turn on the unit.

For Station 1A:

- ◆ When the heater lamp blinks on and off then it means that the tip temperature has reached the set temperature and is ready for use.

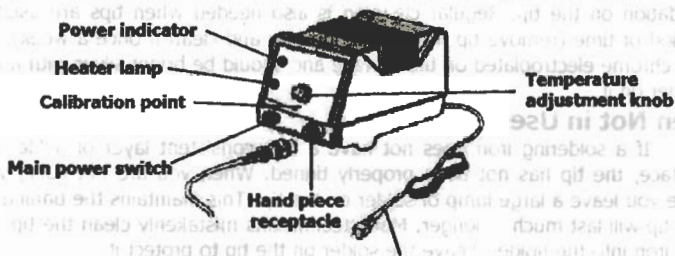

For Station 2A:

1. The Digital display will initially display the current set temperature, after a few seconds it would switch to displaying the actual temperature.
2. Turning the control knob clockwise increases the desired (SET) temperature settings, while turning the knob counter-clockwise decreases the desired (SET) temperature settings. The display would increase and decrease accordingly showing the SET temperature. If the knob is left unmoved, the display would switch from showing the SET temperature to showing the actual temperature at the tip of the soldering iron.
3. The display would show the letters "OFF" if the unit has detected that the soldering iron and the main unit are not connected securely or is not connected. If this is displayed, turn off the unit and reattach firmly the soldering iron to the receptacle at the main unit.

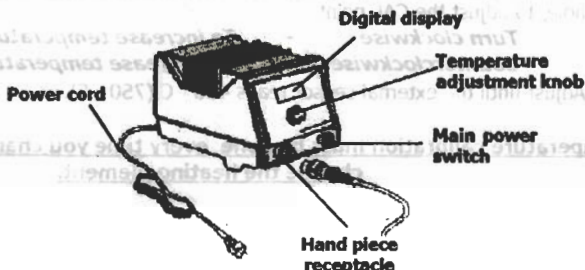

SOLDER TIP CARE and MAINTENANCE

Tip Temperature

If the tip temperature is too high, it decreases the life of the tip. So we suggest you to use the lowest *possible* tip temperature when soldering. This not only prolong life of the tip, it also quickens heat recovery and decreases harm to sensitive components.

Cleaning

The soldering iron tip should be cleaned after use by wiping it on the damp sponge found in the soldering iron stand, this is to get rid of burnt solder or fluxes that causes oxidation on the tip. Regular cleaning is also needed when tips are used for prolonged period of time (remove tip from soldering iron and clean it once a week). The solder tips are chrome electroplated on the surface and should be bright silver with no flux residue or solder on it.

When Not in Use

If a soldering iron does not have a thin consistent layer of solder over the entire surface, the tip has not been properly tinned. When you are not using your iron, make sure you leave a large lump of solder on the tip. This maintains the tinning on the tip, and the tip will last much longer. Many technicians mistakenly clean the tip before they put the iron into the holder. Leave the solder on the tip to protect it.

Remember to tin the tip after cleaning in preparation for the next use.

STEPS in Checking, Cleaning and Tinning the Tip

1. Set temperature to 250° C (482° F)
2. After real temperature reaches the set temperature, use a damp sponge to clean the tip and check for damages.
3. If the tip has oxidation, apply solder and wipe using the damp sponge, repeat these steps until oxidation is removed.
4. After cleaning, coat tip with a thin layer of solder and set it aside ready for the next usage.
5. If the tip shows disfiguration or has rust on it. Change the tip.
Never use file or sharp rough objects in removing oxidation of the tip

STEPS in Calibrating the Tip Temperature

1. Plug in station and turn it on.
2. Set temperature to 400° C (750° F)
3. Wait for Heater LED to light up.
4. Use an external sensor and place it on the solder tip.
5. Take off the rubber stop in the CAL point. Use a screwdriver, one that fits the CAL hole, to adjust the CAL point.
Turn clockwise - To increase temperature
Counterclockwise - To decrease temperature
6. Adjust until the external sensor reads 400° C (750° F).

Temperature calibration must be done every time you change the solder tip or change the heating element.

DISASSEMBLING THE HAND PIECE

The hand piece may be disassembled for trouble shooting and repair:

1. Turn off main station and unplug from power source.
2. Detach the Soldering Iron Receptacle ("15" as shown below) from the main unit.
3. Turn the Copper Nut, ("1" as shown) counter clockwise to loosen it.
4. Pull out the Tip Enclosure ("2"), the Solder Tip ("3"), Tip Lock ("4").
5. Turn the Plastic Nut ("5") counter clockwise to release it from the main body.
6. Push out the Heating Element ("6") via the Wire Cord ("14").

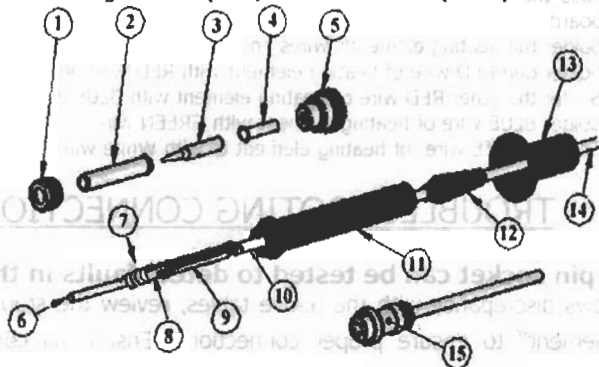

To reassemble the hand piece:

1. Slide in hand piece PCB into the main handle. Be sure to secure the PCB in the notch at the mouth of the main handle.
2. Attach the front module "5" to the main handle.
3. Slide in the Tip holder "4". Make sure the smaller end is inserted first. Insert the soldering iron tip "3" as seen below.
4. Secure the tip by inserting the tip enclosure "2" and nut "1" securely.

To test if the heating element is in working condition:

Cool down assembly to room temperature before continuing the tests below:

1. Follow "Disassembling the hand piece" guide.
2. Do the following tests on the hand piece PCB board:
Resistance value of heating element (RED/ Blue pair) 19 to 23 Ω
Resistance value of sensor (Green /White pair) 1.2 to 1.5 Ω

After testing check results with the following:

- ♦ If the resistance value is not as stated above replace the heating element.
- ♦ If a 0 Ω or infinite resistances are measured check for shorts or open circuits.
- ♦ Intermittent readings can also be caused by cold solder double check solder points if the heating element has recently been replaced.

To replace the heating element follow "Replacing the heating element" guide on the next page

REPLACING THE HEATING ELEMENT

The heating element can be replaced as follows:

1. Follow the steps in "disassembling the soldering iron".
 2. Unsolder the heating element wires (Red/RED) and the sensor wires (blue / white).
 3. The old heating element can now be detached from the hand piece board.
 4. Detach the metal protector located at the bottom part of the heating element.
 5. Reattach the metal protector to the bottom part of the new heating element.
 6. Pass the New heating elements wires (RED) thru the holes located on top of the board.
 7. Solder the heating element's wires and the sensor wires to the board.
- ◆ Solder one RED wire of heating element with RED wire on PCB.
 - ◆ Solder the other RED wire of heating element with BLUE wire on PCB.
 - ◆ Solder BLUE wire of heating element with GREEN wire on PCB.
 - ◆ Solder WHITE wire of heating element to with White wire on PCB

TROUBLESHOOTING CONNECTIONS

The 5 pin socket can be tested to detect faults in the hand piece:

If test shows discrepancy with the above tables, review the steps in "replacing the heating element" to ensure proper connections. Ensure all conditions presented

Pins 4 & 2	∞
Pins 4 & 1	∞
Pins 5 & 1	∞
Pins 5 & 2	∞



Pins 1 & 2	19 to 23 Ω
Pins 4 & 5	1.2 to 1.5 Ω
Pin 3 & solder tip	Below 2 Ω

above are met **before plugging in the hand piece**. Failure to do so can damage the internal circuitry of the unit.

Follow the following direction to test for hand piece cord faults:

Test 1: Rendering physical strain to the cord

1. Turn on the unit.
2. Set temperature to 480 °C.
3. Bend and straiten the entire length of the cord bit by bit. The heater lamp should always be lit while doing so. If the heater lamp becomes intermittent the cord is faulty and should be replaced.

Note: the Heater lamp will blink if the temperature of the soldering iron tip has reached the set temperature i.e. 480°C. this is not an indication of a faulty cord.

TROUBLESHOOTING CONNECTIONS

Test 2: Resistance test

1. Follow the steps in disassembling the hand piece .
2. Test for continuity between the following pins and colored wires at the hand piece PCB, all tests should register 0 to 2 Ω .
3. If any of the above mentioned combination does not register 0 Ω the cord is faulty and should be replaced.
4. See our "replacing the soldering iron cord"guide.

Pin 1 & RED wire	Pin 2 & BLUE wire
Pins 3 & BLACK wire	Pin 4 & GREEN wire
Pin 5 & WHITE wire	

REPLACING SOLDERING IRON CORD

When cord is proven to be faulty follow the steps to replace the cord:

1. Follow the steps in disassembling the hand piece.
2. Write down or make a brief illustration of wire configuration in the PCB.
3. Unsolder the wires connecting the hand piece PCB and cord together.
4. Unattached the BLACK wire, connecting the cord and grounding spring together.
5. Detach the PCB from the cord by releasing the metal grips located at the bottom of the PCB .
6. Slide out the main handle , soft grip pad and tail end of the hand piece.
7. Insert the tail end and soft grip pad into the new cord.
8. Insert the new cord thought the main handle.
9. Solder the wires back into the PCB, using the proper configurations.
10. Reattach the from the new cord to the grounding spring.
11. Bend the metal on the bottom end of the PCB to grip the cord firmly.
12. Follow "Reassembly of hand piece" procedure to complete the process.

Connection table:

PIN	CORD COLOR	CORD COLOR	Heating element
1	RED	RED	RED
2	BLUE	BLUE	RED
3	BLACK	BLACK	SPRING
4	GREEN	GREEN	BLUE
5	WHITE	WHITE	WHITE (translucent)

CHANGING THE FUSE

Checking/ Changing the fuse:

The Fuse can be found at the back of the unit, it is incorporated into the AC power receptacle. If fuse is blown replace with same type fuse only.

1. Use a screw driver to pop open the fuse holder, slide the fuse holder out.
2. Check if the fuse in use is blown. If blown/damaged, detach the spare fuse and attach to the active fuse holder.)
3. Reattach the fuse holder.

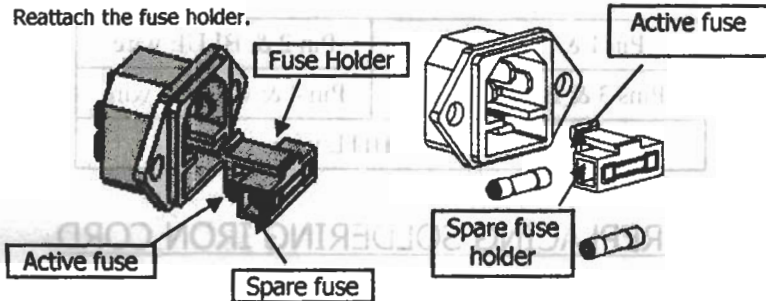

BASIC TROUBLESHOOTING GUIDE

WARNING: To avoid personal injury or equipment damage, disconnect power cords before making any servicing to the equipment, or unless instructed otherwise in the troubleshooting procedures.

PROBLEM 1: THE UNIT HAS NO POWER /MAIN POWER LED DOES NOT LIGHT UP

1. Check if the unit is switched ON.
2. Check the fuse. Replace with the same type of fuse if blown.
3. Check the power cord and make sure there are no disconnections.
4. Verify that the unit is properly connected to the power source.

Additional precautions :

- ◆ Check internal circuitry for shorts that may cause the blown fuse.

PROBLEM 2: SOLDERING IRON DOES NOT RISE IN TEMPERATURE

Description: Main power LED lights up and so does the heater LED but soldering iron temperature is relative low and is not heating up.

SOLUTION:

1. Soldering iron cord may be damaged and needs to be replaced or repaired.
2. Heating element may be damaged and needs to be replaced .

BASIC TROUBLESHOOTING GUIDE

PROBLEM 3: SOLDERING IRON TEMPERATURE IS INTERMITTENT

Description: *Main power LED lights up and so does the heater LED but soldering iron temperature rises and falls uncontrollably.*

SOLUTION:

- ◆ Soldering iron plug may be loose from the receptacle unplug the soldering iron and reattach.
- ◆ Soldering iron cord may be damaged or loose and needs to be replaced or repaired. See trouble shooting soldering iron cords section of this manual.

PROBLEM 4: SOLDER WOULD NOT STICK TO THE SOLDERING TIP

Description: *Soldering iron is able to quickly melt solder but cannot cause the solder to attach to the tip.*

SOLUTION:

- ◆ Soldering iron tip may already be too dirty or oxidized . Please see our solder tip maintenance guide on how to clean soldering tips.
- ◆ Temperature could be set too high causing solder to quickly burn away Please adjust to a more suitable lower temperature range.

PROBLEM 5: SOLDERING IRON DOES NOT PRODUCE ENOUGH HEAT

Description: *Soldering iron cannot melt solder fast enough, or actual temperature does not reach the desired set temperature.*

SOLUTION:

- ◆ The system may need to be recalibrated please see [steps in calibrating the tip temperature](#)
- ◆ Soldering iron tip may already be too dirty or oxidized . Please see our solder tip maintenance guide on how to clean soldering tips.

PROBLEM 6: Display and other problems not mentioned.

Description: *Display shows unreadable characters.*

SOLUTION:

- ◆ Turn the unit off and then back on after a few seconds.

BASIC TROUBLESHOOTING GUIDE

PROBLEM 3: SOLDERING IRON TEMPERATURE IS INTERMITTENT

Description: Main power LED lights all and flashes the heater LED but soldering iron temperature does not rise uncontrollably.

SOLUTION:

- Soldering iron plug and cables look

normal.

- Soldering iron cord may be damaged or loose and needs to be replaced or repaired.

See trouble shooting soldering iron cords section of this manual.

PROBLEM 4: SOLDER WOULD NOT STICK TO THE SOLDERING TIP

Description: Soldering iron would not dunk into solder but cannot cause the solder to attach to the tip.

SOLUTION:

- Soldering iron tip may already be too dirty or oxidized. Please see our solder tip maintenance guide on how to clean soldering tips.
- Temperature could be set too low. Please refer to soldering iron manual for more suitable lower temperature range.

PROBLEM 5: SOLDERING IRON DOES NOT PRODUCE FINE POINTS

Description: Soldering iron would produce very thick solder but cannot produce a fine point. Please refer to soldering iron manual for more suitable temperature range.

SOLUTION:

- The system may need to be recalibrated based on [steps in calibrating the IR temperature](#).
- Soldering iron tip may already be too dirty or oxidized. Please see our solder tip maintenance guide on how to clean soldering tips.

PROBLEM 6: Display and other problems not mentioned.

Description: Display shows unexpected characters.

SOLUTION:

- Turn the unit off and check back on after a