

MC1374

TV Modulator Circuit

The MC1374 includes an FM audio modulator, sound carrier oscillator, RF oscillator, and RF dual input modulator. It is designed to generate a TV signal from audio and video inputs. The MC1374's wide dynamic range and low distortion audio make it particularly well suited for applications such as video tape recorders, video disc players, TV games and subscription decoders.

- Single Supply, 5.0 V to 12 V
- Channel 3 or 4 Operation
- Variable Gain RF Modulator
- Wide Dynamic Range
- Low Intermodulation Distortion
- Positive or Negative Sync
- Low Audio Distortion
- Few External Components

TV MODULATOR CIRCUIT

SEMICONDUCTOR TECHNICAL DATA

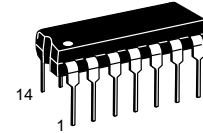

P SUFFIX
PLASTIC PACKAGE
CASE 646

ORDERING INFORMATION

Device	Operating Temperature Range	Package
MC1374P	T _A = 0° to +70°C	Plastic DIP

Figure 1. Simplified Application

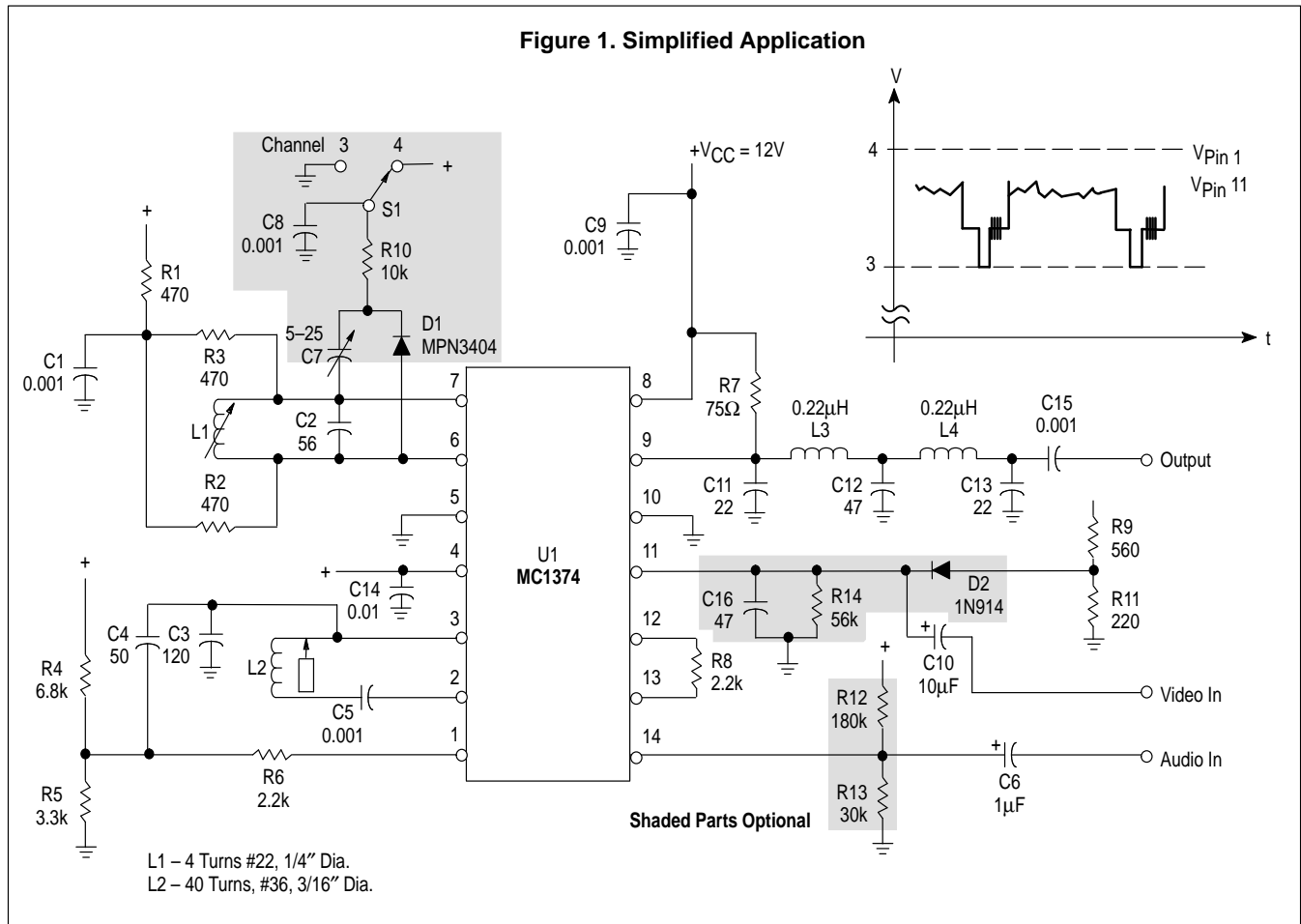

MC1374

MAXIMUM RATINGS (T_A = 25°C, unless otherwise noted.)

Rating	Value	Unit
Supply Voltage	14	Vdc
Operating Ambient Temperature Range	0 to +70	°C
Storage Temperature Range	-65 to +150	°C
Junction Temperature	150	°C
Power Dissipation Package Derate above 25°C	1.25 10 mW/°C	W

ELECTRICAL CHARACTERISTICS (V_{CC} = 12 Vdc, T_A = 25°C, f_c = 67.25 MHz, Figure 4 circuit, unless otherwise noted.)

Characteristics	Min	Typ	Max	Unit
AM OSCILLATOR/MODULATOR				
Operating Supply Voltage	5.0	12	12	V
Supply Current (Figure 1)	–	13	–	mA
Video Input Dynamic Range (Sync Amplitude)	0.25	1.0	1.0	V Pk
RF Output (Pin 9, R7 = 75 Ω, No External Load)	–	170	–	mV pp
Carrier Suppression	36	40	–	dB
Linearity (75% to 12.5% Carrier, 15 kHz to 3.58 MHz)	–	–	2.0	%
Differential Gain Distortion (IRE Test Signal)	5.0	7.0	10	%
Differential Phase Distortion (3.58 MHz IRE Test Signal)	–	1.5	2.0	Degrees
920 kHz Beat (3.58 MHz @ 30%, 4.5 MHz @ 25%)	–	-57	–	dB
Video Bandwidth (75 Ω Input Source)	30	–	–	MHz
Oscillator Frequency Range	–	105	–	MHz
Internal Resistance across Tank (Pin 6 to Pin 7)	–	1.8	–	kΩ
Internal Capacitance across Tank (Pin 6 to Pin 7)	–	4.0	–	pF

ELECTRICAL CHARACTERISTICS (T_A = 25°C, V_{CC} = 12 Vdc, 4.5 MHz, Test circuit of Figure 11, unless otherwise noted.)

Characteristics	Min	Typ	Max	Unit
FM OSCILLATOR/MODULATOR				
Frequency Range of Modulator	14	4.5	14	MHz
Frequency Shift versus Temperature (Pin 14 open)	–	0.2	0.3	kHz/°C
Frequency Shift versus V _{CC} (Pin 14 open)	–	–	4.0	kHz/V
Output Amplitude (Pin 3 not loaded)	–	900	–	mVpp
Output Harmonics, Unmodulated	–	–	-40	dB
Modulation Sensitivity				MHz/V
1.7 MHz	–	0.20	–	
4.5 MHz	–	0.24	–	
10.7 MHz	–	0.80	–	
Audio Distortion (±25 kHz Deviation, Optimized Bias Pin 14)	–	0.6	1.0	%
Audio Distortion (±25 kHz Deviation, Pin 14 self biased)	–	1.4	–	
Incidental AM (±25 kHz FM)	–	2.0	–	
Audio Input Resistance (Pin 14 to ground)	–	6.0	–	kΩ
Audio Input Capacitance (Pin 14 to ground)	–	5.0	–	pF
Stray Tuning Capacitance (Pin 3 to ground)	–	5.0	–	pF
Effective Oscillator Source Impedance (Pin 3 to load)	–	2.0	–	kΩ

MC1374

Figure 2. TV Modulator

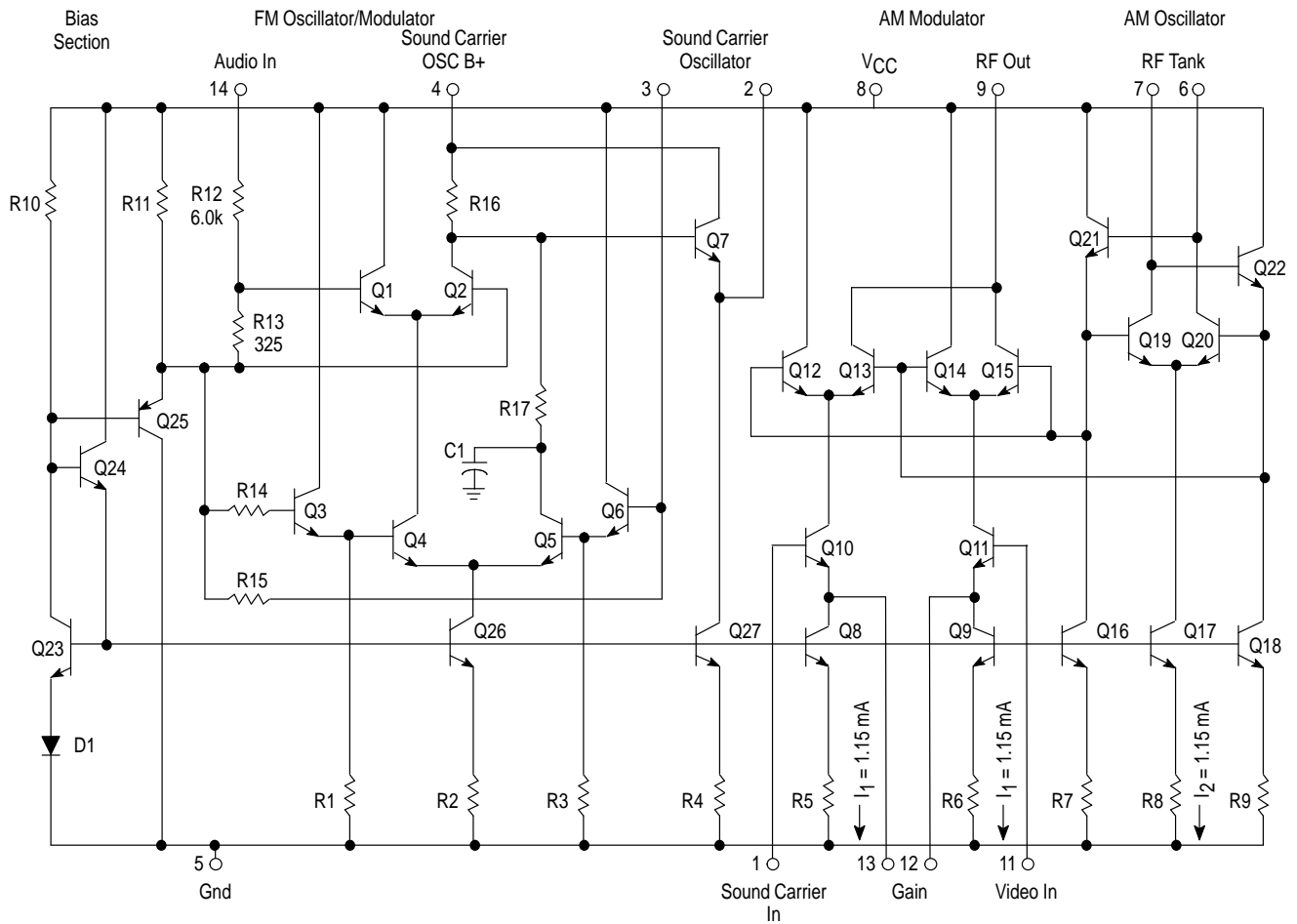

GENERAL INFORMATION

The MC1374 contains an RF oscillator, RF modulator, and a phase shift type FM modulator, arranged to permit good printed circuit layout of a complete TV modulation system. The RF oscillator is similar to the one used in MC1373, and is coupled internally in the same way. Its frequency is controlled by an external tank on Pins 6 and 7, or by a crystal circuit, and will operate to approximately 105 MHz. The video modulator is a balanced type as used in the well known MC1496. Modulated sound carrier and composite video information can be put in separately on Pins 1 and 11 to minimize unwanted crosstalk. A single resistor on Pins 12 and 13 is selected to set the modulator gain. The RF output at Pin 9 is a current source which drives a load connected from Pin 9 to V_{CC} .

The FM system was designed specifically for the TV intercarrier function. For circuit economy, one phase shift circuit was built into the ship. Still, it will operate from 1.4 MHz to 14 MHz, low enough to be used in a cordless telephone

base station (1.76 MHz), and high enough to be used as an FM IF test signal source (10.7 MHz). At 4.5 MHz, a deviation of ± 25 kHz can be achieved with 0.6% distortion (typical).

In the circuit above, devices Q1 through Q7 are active in the oscillator function. Differential amplifier Q3, Q4, Q5, and Q6 acts as a gain stage, sinking current from input section Q1, Q2 and the phase shift network R17, C1. Input amplifier Q1, Q2 can vary the amount of "in phase" Q4 current to be combined with phase shifter current in load resistor R16. The R16 voltage is applied to emitter follower Q7 which drives an external L-C circuit. Feedback from the center of the L-C circuit back to the base of Q6 closes the loop. As audio input is applied which would offset the stable oscillatory phase, the frequency changes to counteract. The input to Pin 14 can include a dc feedback current for AFC over a limited range.

The modulated FM signal from Pin 3 is coupled to Pin 1 of the RF modulator and is then modulated onto the AM carrier.

AM Section

The AM modulator transfer function in Figure 3 shows that the video input can be of either polarity (and can be applied at either input). When the voltages on Pin 1 and Pin 11 are equal, the RF output is theoretically zero. As the difference between $V_{Pin\ 11}$ and $V_{Pin\ 1}$ increases, the RF output increases linearly until all of the current from both I_1 current sources (Q8 and Q9) is flowing in one side of the modulator. This occurs when $\pm(V_{Pin11} - V_{Pin1}) = I_1 R_G$, where I_1 is typically 1.15 mA. The peak-to-peak RF output is the $2I_1 R_L$. Usually the value of R_L is chosen to be $75\ \Omega$ to ease the design of the output filter and match into TV distribution systems. The theoretical range of input voltage and R_G is quite wide, but noise and available sound level limit the useful video (sync tip) amplitude to between 0.25 Vpk and 1.0 Vpk. It is recommended that the value of R_G be chosen so that only about half of the dynamic range will be used at sync tip level.

The operating window of Figure 5 shows a cross-hatched area where Pin 1 and Pin 11 voltages must always be in order to avoid saturation in any part of the modulator. The letter ϕ represents one diode drop, or about 0.75 V. The oscillator Pins 6 and 7 must be biased to a level of $V_{CC} - \phi - 2I_1 R_L$ (or lower) and the input Pins 1 and 11 must always be at least 2ϕ below that. It is permissible to operate down to 1.6 V, saturating the current sources, but whenever possible, the minimum should be 3ϕ above ground.

The oscillator will operate dependably up to about 105 MHz with a broad range of tank circuit component values. It is desirable to use a small L and a large C to minimize the dependence on IC internal capacitance. An operating Q between 10 and 20 is recommended. The values of R_1 , R_2 and R_3 are chosen to produce the desired Q and to set the Pin 6 and 7 dc voltage as discussed above. Unbalanced operation, i.e., Pin 6 or 7 bypassed to ground, is not recommended. Although the oscillator will still run, and the modulator will produce a useable signal, this mode causes substantial base-band video feedthrough. Bandswitching, as Figure 1 shows, can still be accomplished economically without using the unbalanced method.

The oscillator frequency with respect to temperature in the test circuit shows less than ± 20 kHz total shift from 0° to 50°C as shown in Figure 7. At higher temperatures the slope approaches $2.0\ \text{kHz}/^\circ\text{C}$. Improvement in this region would require a temperature compensating tuning capacitor of the N75 family.

Crystal control is feasible using the circuit shown in Figure 21. The crystal is a 3rd overtone series type, used in series resonance. The L1, C2 resonance is adjusted well below the crystal frequency and is sufficiently tolerant to permit fixed values. A frequency shift versus temperature of less than $1.0\ \text{Hz}/^\circ\text{C}$ can be expected from this approach. The resistors Ra and Rb are to suppress parasitic resonances.

Coupling of output RF to wiring and components on Pins 1 and 11 can cause as much as 300 kHz shift in carrier (at 67 MHz) over the video input range. A careful layout can keep this shift below 10 kHz. Oscillator may also be inadvertently coupled to the RF output, with the undesired effect of preventing a good null when $V_{11} = V_1$. Reasonable care will yield carrier rejection ratios of 36 to 40 dB below sync tip level carrier.

In television, one of the most serious concerns is the prevention of the intermodulation of color (3.58 MHz) and sound (4.5 MHz) frequencies, which causes a 920 kHz signal to appear in the spectrum. Very little (3rd order) nonlinearity is needed to cause this problem. The results in Figure 6 are unsatisfactory, and demonstrate that too much of the available dynamic range of the MC1374 has been used. Figures 8 and 10 show that by either reducing standard signal level, or reducing gain, acceptable results may be obtained.

At VHF frequencies, small imbalances within the device introduce substantial amounts of 2nd harmonic in the RF output. At 67 MHz, the 2nd harmonic is only 6 to 8 dB below the maximum fundamental. For this reason, a double pi low pass filter is shown in the test circuit of Figure 3 and works well for Channel 3 and 4 lab work. For a fully commercial application, a vestigial sideband filter will be required. The general form and approximate values are shown in Figure 19. It must be exactly aligned to the particular channel.

Figure 3. AM Modulator Transfer Function

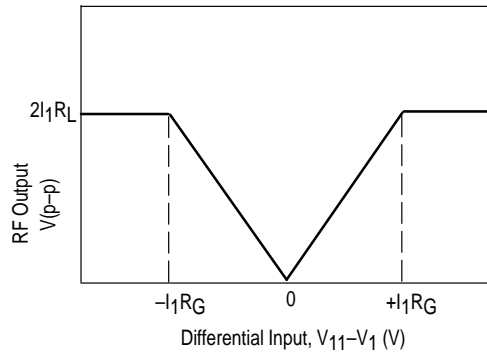

Figure 4. AM Test Circuit

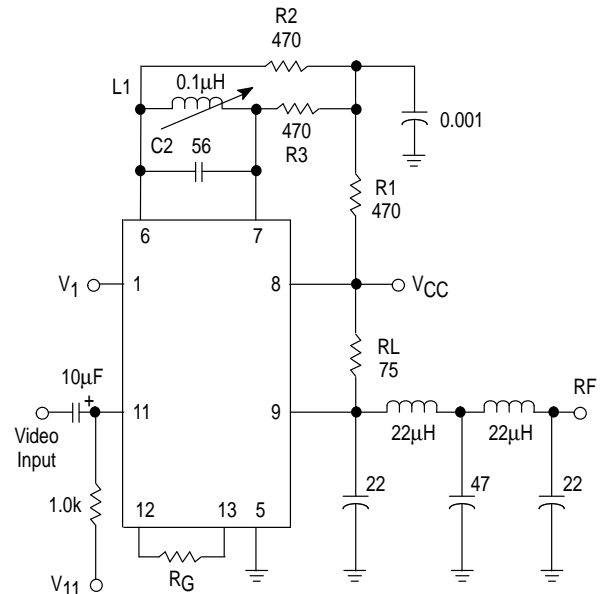

Figure 5. The Operating Window

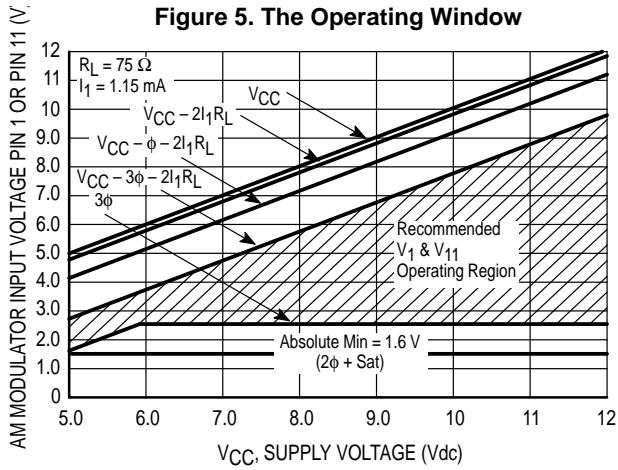

Figure 6. 920 kHz Beat

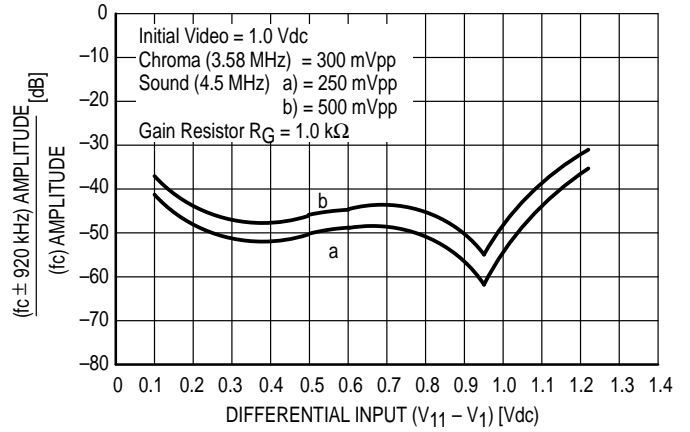

Figure 7. RF Oscillator Frequency versus Temperature

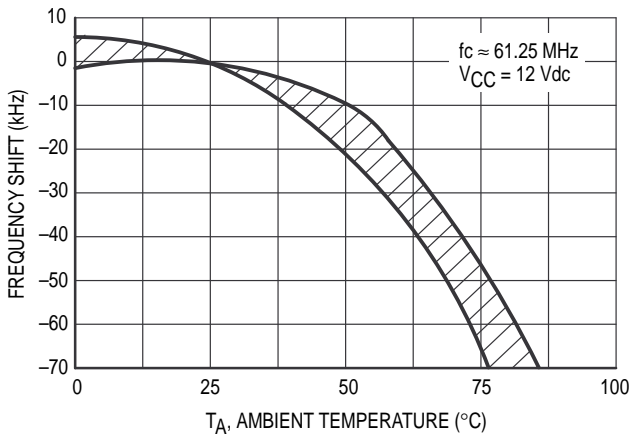

Figure 8. 920 kHz Beat

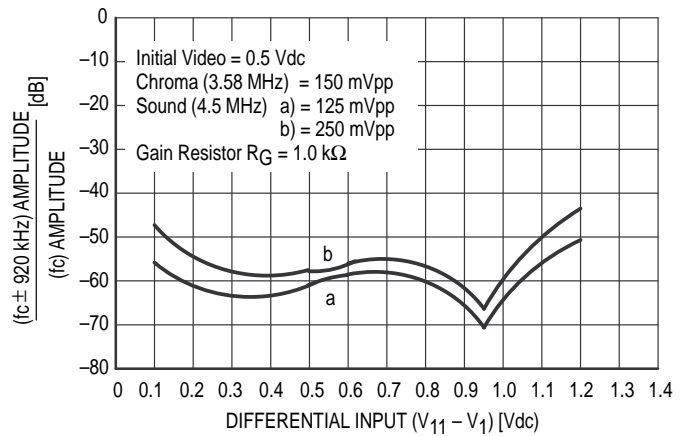

Figure 9. RF Oscillator Frequency versus Supply Voltage

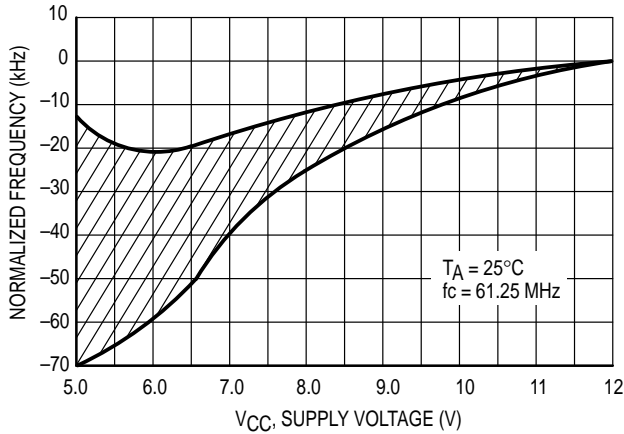
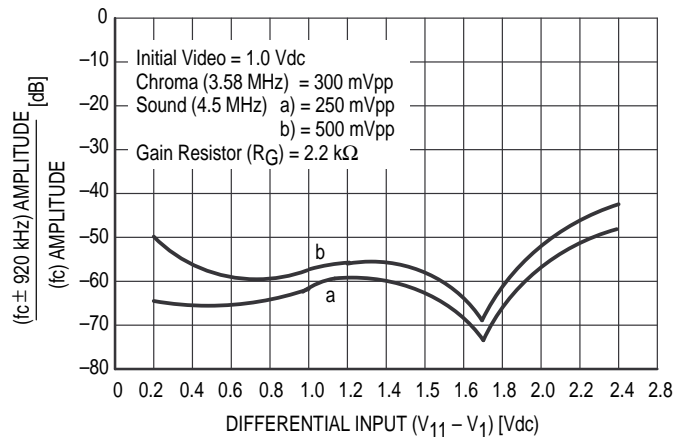

Figure 10. 920 kHz Beat



FM Section

The oscillator center is approximately the resonance of the inductor L_2 from Pin 2 to Pin 3 and the effective capacitance C_3 from Pin 3 to ground. For overall oscillator stability, it is best to keep X_L in the range of 300Ω to $1.0 \text{ k}\Omega$.

The modulator transfer characteristic at 4.5 MHz is shown in Figure 15. Transfer curves at other frequencies have a very similar shape, but differ in deviation per input volt, as shown in Figures 13 and 17.

Most applications will not require DC connection to the audio input, Pin 14. However, some improvements can be achieved by the addition of biasing circuitry. The unaided device will establish its own Pin 14 bias at 4θ , or about 3.0 V. This bias is a little too high for optimum modulation linearity. Figure 14 shows better than 2 to 1 improvement in distortion between the unaided device and pulling Pin 14 down to 2.6 V to 2.7 V. This can be accomplished by a simple divider, if the supply voltage is relatively constant.

The impedance of the divider has a bearing on the frequency versus temperature stability of the FM system. A divider of $180 \text{ k}\Omega$ and $30 \text{ k}\Omega$ (for $V_{CC} = 12 \text{ V}$) will give good temperature stabilization results. However, as Figure 18 shows, a divider is not a good method if the supply voltage varies. The designer must make the decisions here, based on considerations of economy, distortion and temperature requirements and power supply capability. If the distortion requirements are not stringent, then no bias components are needed. If, in this case, the temperature compensation needs to be improved in the high ambient area, the tuning capacitor from Pin 3 to ground can be selected from N75 or N150 temperature compensation types.

Another reason for DC input to Pin 14 is the possibility of automatic frequency control. Where high accuracy of inter-carrier frequency is required, it may be desirable to feed back the DC output of an AFC or phase detector for nominal carrier frequency control. Only limited control range could be used without adversely affecting the distortion performance, but very little frequency compensation will be needed.

One added convenience in the FM section is the separate Pin "oscillator B+" which permits disabling of the sound system during alignment of the AM section. Usually it can be hard wired to the V_{CC} source without decoupling.

Standard practice in television is to provide pre-emphasis of higher audio frequencies at the transmitter and a matching de-emphasis in the TV receiver audio amplifier. The purpose of this is to counteract the fact that less energy is usually present in the higher frequencies, and also that fewer modulation sidebands are within the deviation window. Both factors degrade signal to noise ratio. Pre-emphasis of $75 \mu\text{s}$ is standard practice. For cases where it has not been provided, a suitable pre-emphasis network is covered in Figure 20.

It would seem natural to take the FM system output from Pin 2, the emitter follower output, but this output is high in harmonic content. Taking the output from Pin 3 sacrifices somewhat in source impedance but results in a clean output fundamental, with all harmonics more than 40 dB down. This choice removes the need for additional filtering components.

The source impedance of Pin 3 is approximately $2.0 \text{ k}\Omega$, and the open circuit amplitude is about 900 mV pp for the test circuit shown in Figure 11.

The application circuit of Figure 1 shows the recommended approach to coupling the FM output from Pin 3 to the AM modulator input, Pin 1. The input impedance at Pin 1 is very high, so the intercarrier level is determined by the source impedance of Pin 3 driving through C_4 into the video bias circuit impedance of R_4 and R_5 , about 2.2 k . This provides an intercarrier level of 500 mV pp , which is correct for the 1.0 V peak video level chosen in this design. Resistor R_6 and the input capacitance of Pin 1 provide some decoupling of stray pickup of RF oscillator or AM output which may be coupled to the sound circuitry.

Figure 11. FM Test Circuit

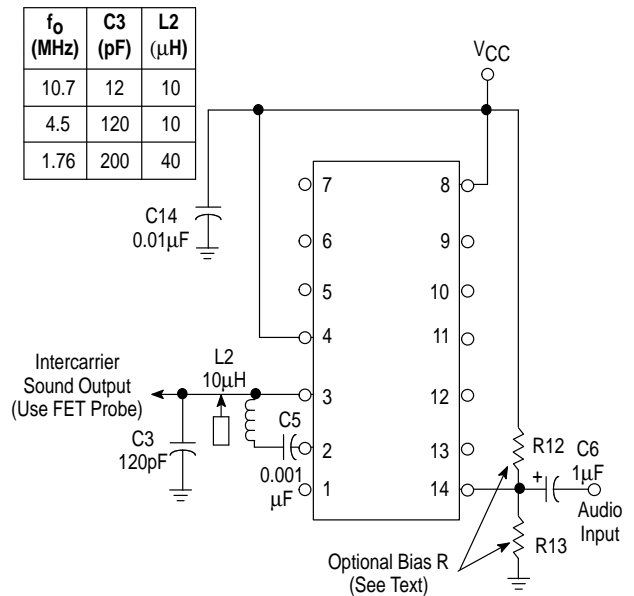

Figure 12. Modulator Sensitivity

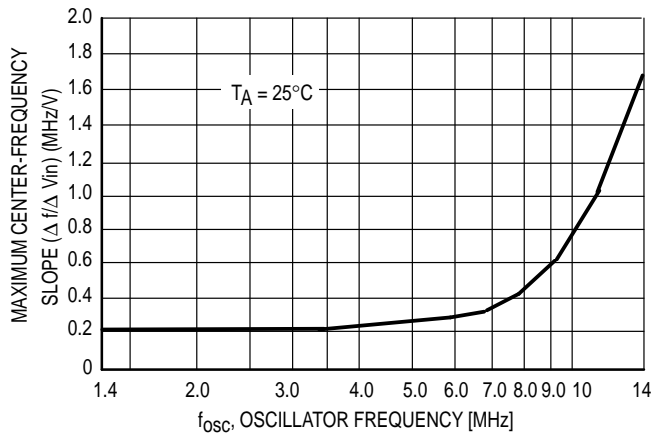

Figure 13. Modulator Transfer Function

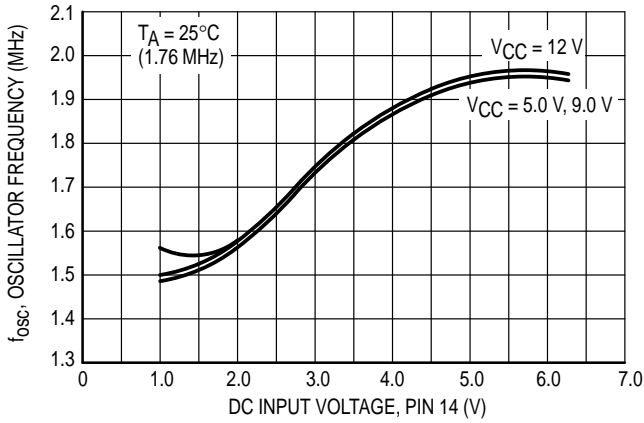

Figure 14. Distortion versus Modulation Depth

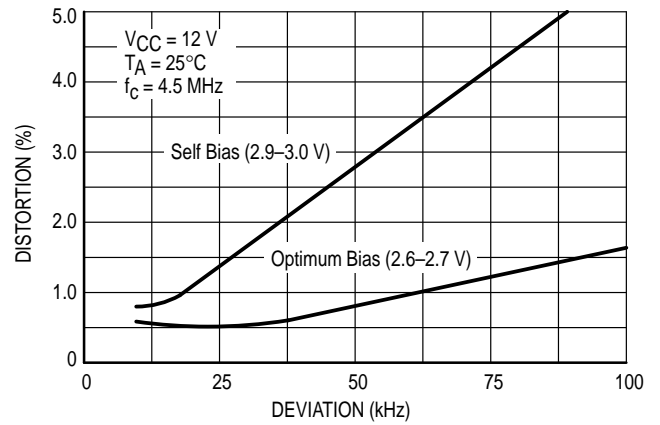

Figure 15. Modulator Transfer Function

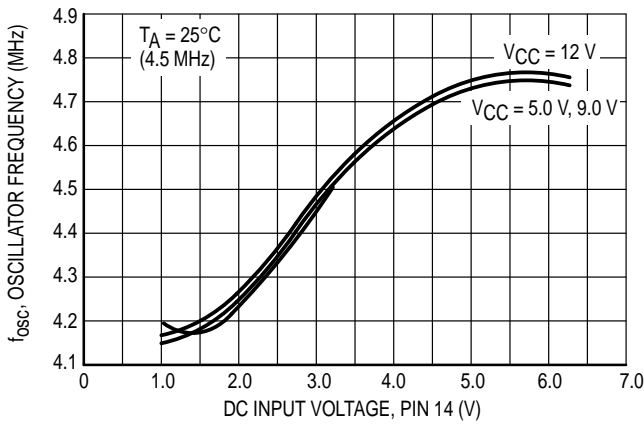

Figure 16. FM System Frequency versus Temperature

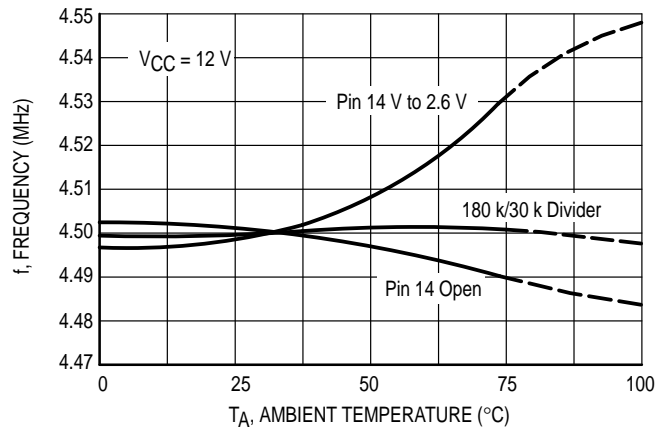

Figure 17. Modulator Transfer Function

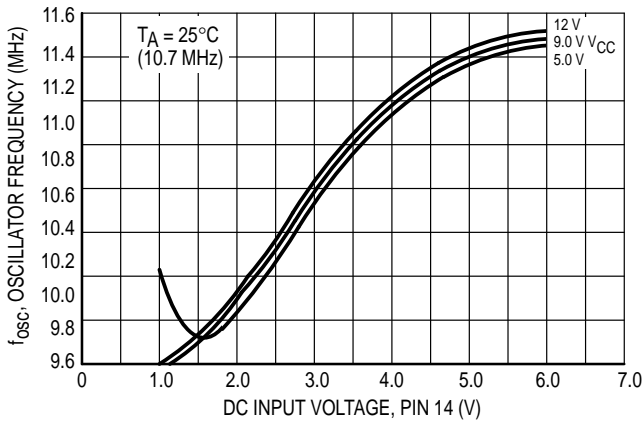

Figure 18. FM System Frequency versus VCC

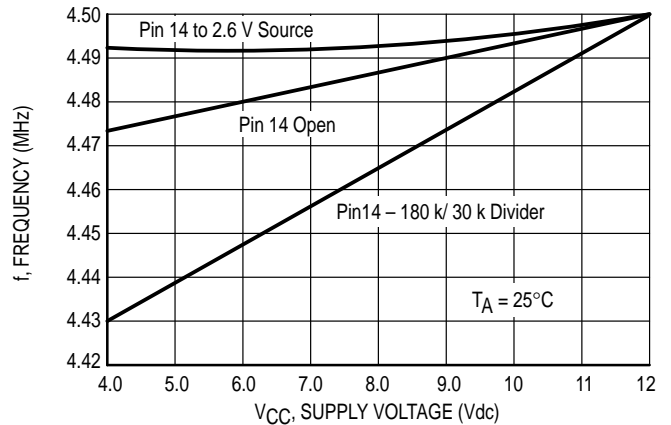

Figure 19. A Channel 4 Vestigial Sideband Filter

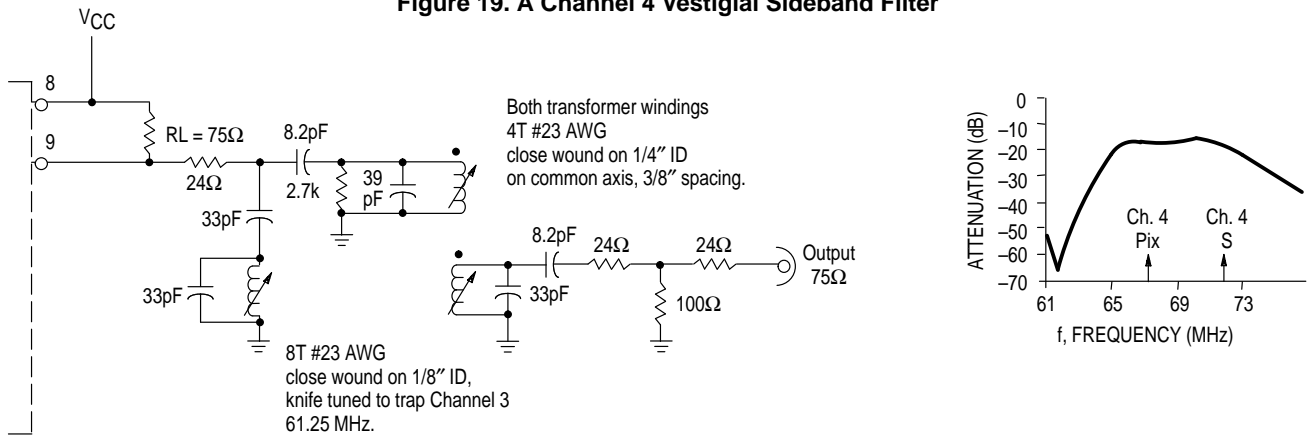

Figure 20. Audio Pre-Emphasis Circuit

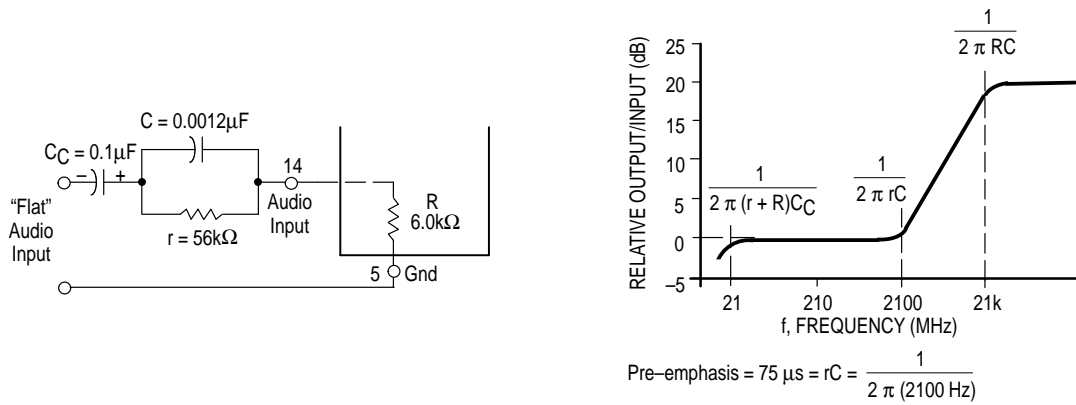
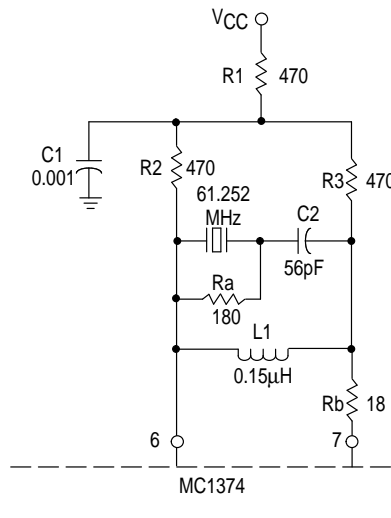

Figure 21. Crystal Controlled RF Oscillator
for Channel 3, 61.25 MHz



NOTE: See Application Note AN829 for further information.

MC1374

OUTLINE DIMENSIONS

P SUFFIX
PLASTIC PACKAGE
 CASE 646-06
 ISSUE L

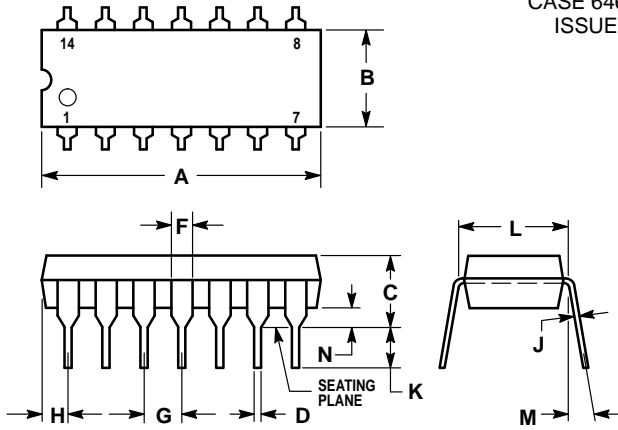

NOTES:

1. LEADS WITHIN 0.13 (0.005) RADIUS OF TRUE POSITION AT SEATING PLANE AT MAXIMUM MATERIAL CONDITION.
2. DIMENSION L TO CENTER OF LEADS WHEN FORMED PARALLEL.
3. DIMENSION B DOES NOT INCLUDE MOLD FLASH.
4. ROUNDED CORNERS OPTIONAL.

DIM	INCHES		MILLIMETERS	
	MIN	MAX	MIN	MAX
A	0.715	0.770	18.16	19.56
B	0.240	0.260	6.10	6.60
C	0.145	0.185	3.69	4.69
D	0.015	0.021	0.38	0.53
F	0.040	0.070	1.02	1.78
G	0.100 BSC		2.54 BSC	
H	0.052	0.095	1.32	2.41
J	0.008	0.015	0.20	0.38
K	0.115	0.135	2.92	3.43
L	0.300 BSC		7.62 BSC	
M	0° - 10°		0° - 10°	
N	0.015	0.039	0.39	1.01

Motorola reserves the right to make changes without further notice to any products herein. Motorola makes no warranty, representation or guarantee regarding the suitability of its products for any particular purpose, nor does Motorola assume any liability arising out of the application or use of any product or circuit, and specifically disclaims any and all liability, including without limitation consequential or incidental damages. "Typical" parameters which may be provided in Motorola data sheets and/or specifications can and do vary in different applications and actual performance may vary over time. All operating parameters, including "Typicals" must be validated for each customer application by customer's technical experts. Motorola does not convey any license under its patent rights nor the rights of others. Motorola products are not designed, intended, or authorized for use as components in systems intended for surgical implant into the body, or other applications intended to support or sustain life, or for any other application in which the failure of the Motorola product could create a situation where personal injury or death may occur. Should Buyer purchase or use Motorola products for any such unintended or unauthorized application, Buyer shall indemnify and hold Motorola and its officers, employees, subsidiaries, affiliates, and distributors harmless against all claims, costs, damages, and expenses, and reasonable attorney fees arising out of, directly or indirectly, any claim of personal injury or death associated with such unintended or unauthorized use, even if such claim alleges that Motorola was negligent regarding the design or manufacture of the part. Motorola and  registered trademarks of Motorola, Inc. Motorola, Inc. is an Equal Opportunity/Affirmative Action Employer.

How to reach us:

USA/EUROPE/Locations Not Listed: Motorola Literature Distribution;
P.O. Box 20912; Phoenix, Arizona 85036. 1-800-441-2447 or 602-303-5454

MFAX: RMFAX0@email.sps.mot.com – TOUCHTONE 602-244-6609
INTERNET: <http://Design-NET.com>

JAPAN: Nippon Motorola Ltd.; Tatsumi-SPD-JLDC, 6F Seibu-Butsuryu-Center,
3-14-2 Tatsumi Koto-Ku, Tokyo 135, Japan. 03-81-3521-8315

ASIA/PACIFIC: Motorola Semiconductors H.K. Ltd.; 8B Tai Ping Industrial Park,
51 Ting Kok Road, Tai Po, N.T., Hong Kong. 852-26629298



This datasheet has been download from:

www.datasheetcatalog.com

Datasheets for electronics components.